

# **Martin Road, Badgerys Creek**

## **Dewatering Infrastructure Plan**

### **Water Transfer to Western Sydney Airport**

**Project Application Number:** 10\_0014  
**Project:** Badgerys Creek Quarry and Brick Making Project  
**Date:** 29 September 2020  
**Revision:** 2

#### **Background**

The site at Badgerys Creek is owned by PGH Pavers & Bricks Pty Limited (PGH), which is a subsidiary of CSR Limited (CSR). The property features a brickplant with 3 large water bodies containing approximately 1,000ML, which are former quarry pits that have filled with surface water that drains into them. The plant was mothballed by the previous owners in 2012.

In 2019, Modification 3 & 4 was lodged to amend the approval to facilitate Pit Dewatering, VENM importation and Manufacturing upgrades. Modification 3 & 4 was approved in August 2020 (the Approval).

The Western Sydney Airport (WSA) construction site is located on the other side of Badgerys Creek, to the west of the property. Given the geographical adjacency CSR engaged with WSA about their water requirements and during this process it was established that PGH did not own the water, which lead to discussions with the Natural Resources Access Regulator (NRAR).

On 3 June 2020 PGH entered into an Enforceable Undertaking (EU) with NRAR, which outlined:

1. The basis of an agreement to supply WSA with stored water from the Badgerys Creek PGH site, thus preventing further extraction of water that would otherwise be required to facilitate development works by WSA.
2. A requirement that PGH purchase the water, at twice its value, that was unlawfully taken under s60G of the Water Management Act 2000
3. The obligation to undertake works by 2 December 2020 to prevent the capture of surface water in the form of rainfall runoff.

A Water Access Licence to supply the pit water has been agreed between PGH and WSA Co Limited ("WSA Co"), which is the government business enterprise established to develop and operate Western Sydney International (Nancy Bird Walton) Airport at Badgerys Creek. This water will be used by WSA Co for dust suppression purposes during the construction phase and will be transferred using the pipework infrastructure outlined in this plan.

## Statutory Approvals and Requirements

Schedule 3, Condition 23A of the Approval sets out the following requirements in relation to a Dewatering Infrastructure Plan (DIP):

### Dewatering Infrastructure Plan

23A. Prior to carrying out any construction activities associated with the dewatering activities on the site, the Proponent must prepare a Dewatering Infrastructure Plan for the project to the satisfaction of the Secretary. This plan must include:

- (a) detailed designs for:
  - any pipeline infrastructure used for dewatering activities; and
  - the method to be used to cross Badgerys Creek;
- (b) a flooding assessment which:
  - considers the impacts of any structures (including overland pipelines) to flood flow within the floodplain up to the PMF; and
  - describes the measures that will be implemented to minimise those impacts; and
- (c) a description of the measures to be implemented for:
  - managing construction and operation of minor surface infrastructure;
  - avoiding significant impacts and minimisation of impacts generally;
  - controlling any potential water pollution from construction;
  - minimising and managing erosion and sedimentation;
  - decommissioning of pipeline infrastructure; and
  - rehabilitating disturbed areas.

The Proponent must implement the Dewatering Infrastructure Plan as approved by the Secretary.

Satisfaction of the above requirements of this condition are detailed within this plan as follows:

- (a) Detailed designs – these are contained within the supporting documentation, including plans that illustrate details of the pipeline and the method of crossing Badgerys Creek
- (b) Flooding Assessment –the pipeline and associated infrastructure has been specifically to avoid the lower lying flood affected areas of the site, which means that a specific flood assessment is not required
- (c) Implementation measures – a detailed overview is provided throughout this plan and includes:
  - Construction Management Plan
  - Design measures incorporated to avoid impacts
  - Measures to avoid water pollution, erosion and sedimentation
  - Decommissioning and rehabilitation plan.

### Supporting documentation

All construction activities required to facilitate the dewatering activities to supply water for use at the WSA construction site will be completed in accordance with the DIP, which includes:

1. CPB Contractors/Lendlease (the contractor) Work Pack for the NPE – CSR Water Installation associated with the WSA Bulk Earthworks Rev 1
2. Drawings titled:
  - a. “Western Sydney Airport Water Transfer Project General Arrangement”
  - b. “Western Sydney Airport Water Transfer Project Layout (Stage 1)”
  - c. “Western Sydney Airport Water Transfer Project Layout Detail (Stage 1)”

- d. "Western Sydney Airport Pump & Standpipe Package General Arrangement"
  - e. "Western Sydney Airport Creek Crossing Details" Updated 30/9/2020
  - f. "Proposed CSR Water Main – Badgerys Creek Crossing"
  - g. "Western Sydney Airport Discharge Flowmeter & Air Valve (Stage 1) Details"
  - h. "Western Sydney Airport Water Transfer Project Layout (Stage 2)"
  - i. "CSR Water Supply"
3. Sedimentation and Erosion Control Plans – Badgerys Creek ("SECP")

### **Design overview**

The pipeline for the transfer of the water from Pit 1 at the CSR Badgerys Creek site will utilise a submersible pump to enable the transfer of water to the WSA site via a network of pipework that will be constructed by the contractor in accordance with the attached drawings.

From the edge of Pit 1 the pipeline will be located on the surface, but to avoid issues with potential flooding the pipeline will be underbored from the level just above RL54 on CSR's property (the Probable Maximum Flood (PMF) level) across to the WSA site. This will avoid any conflict with flowing or flood water, while still enabling the pipeline to cross underneath Badgerys Creek.

This design will ensure that there is no requirement for any structures or overland pipelines in areas that could impede the flow of flood water. Specific detail of this underboring is illustrated in Drawings (e) & (f) noted above.

### **Flooding Assessment**

The PMF level in the area of the dewatering infrastructure crossing is RL 54. To avoid any issues in the unlikely event of a PMF event, all of the dewatering infrastructure has been designed so that it is below ground where the surface of the land is lower than RL54. The only infrastructure that this could impact is the actual pipeline, which will be bored a minimum of 2m underneath Badgerys Creek in the area where the pipeline is in the zone below RL54.

The absence of any above ground infrastructure in the PMF affected area of Badgerys Creek means that no further flooding assessment is required.

### **Construction Management Plan**

The works to install and remove the pipeline will be undertaken in accordance with the Work Pack, the attached drawings and the SECP. This integrated approach will ensure that there is comprehensive management and control of erosion and sedimentation associated with the works. Upon completion of the construction works all disturbed areas will be revegetated by the contractor to replicate the vegetation prior to the pipeline installation.

Decommissioning of the pipeline following dewatering will implement the same measures and any waste associated with removal of the pipeline infrastructure will be disposed of at an approved waste management facility.

### **Operation of surface mounted infrastructure**

The pump located at the CSR Pit will be mains powered, as per drawing (b). This drawing shows connection from the Stage 1 Pump (90kW-HV Submersible pump) to the power source located near the CSR factory. The Pump will be controlled by a telemetry system, which is operated by WSA contractor engineers. This system incorporates a flowmeter and level sensors to stop the water from overtopping the discharge point on the WSA site. Separate pumps and standpipes are then utilised to pump this water within the WSA site.

### **Avoiding significant impacts and minimising impacts generally**

Detailed planning combined with comprehensive processes and procedures have been adopted to ensure the project is implemented and operated without causing unintended impacts. These are detailed throughout the Work Pack and specifically Section 12 of the document.

### **Decommissioning of the pipeline infrastructure and rehabilitation of disturbed areas**

Detailed information on the demobilisation of the pipeline is contained in Section 14 of the Work Pack. Following the completion of the pipeline infrastructure the area will be rehabilitated with vegetation and landscaped to match the surrounding area, consistent with the condition of the land prior to the installation of the infrastructure.

### **Reporting & Monitoring Program**

The construction and implementation of the pipeline infrastructure will be managed via a Project Control Group (PCG) that will meet regularly prior to and during the construction and commissioning phase of the project. This PCG structure will be repeated during the decommissioning phase and will include representatives from WSA Co, the contractor (including their pipeline sub contractor NPE) and CSR.

The PCG structure will monitor compliance with the DIP and provide for the necessary reporting and notification associated with the implementation and decommissioning phases, including the measures required to address and communicate any incidents, complaints or non-compliances.

Following completion of the implementation phase a regular Operational Review Group (ORG) will be established and scheduled to review the operation of the pipeline. This will occur monthly initially to address any unforeseen issues and when appropriate will be scheduled to occur quarterly to review transfer data and monitor and address any issues as required.

### **Contingency Plan**

The PCG structure will incorporate detailed planning around the implementation and decommissioning phases, but will also include regular and ongoing risk assessments and plans should unforeseen circumstances arise. This structure will include a responsibility matrix and reporting / notification guidelines, that detail the appropriate protocols and parties for recording and reporting any issues and/or incidents

### **Non-Compliance Notification Procedure**

A core component of the reporting and processes associated with the PCG and ORG structure will be to ensure that there is a process established and responsibilities assigned for managing, reporting and addressing any incidents, complaints or non-compliance with statutory requirements. In addition to PCG reports and minutes this procedure will include the establishment of a register, which will detail the particular event and the steps taken to address them, including any associated communication and documentation.

The transition from the PCG to ORG structure will include common representatives from WSA and CSR to ensure that there is a sound knowledge of the project and the history is maintained throughout the forecast 3 year life of the project.

### **Plan review**

The PCG and ORG procedures will ensure that the suitability and operation of the DIP is considered at least once every 6 months or earlier as required. Should it be determined a change is required to the DIP then it will be updated and submitted to the Secretary for approval.

### **Document Control Table**

<b>Plan Name</b>	Dewatering Infrastructure Plan	
<b>Version Number:</b>	2	
<b>Version Date:</b>	29 September 2020	
<b>Prepared by:</b>	Andrew O'Neill	Senior Development Manager
<b>Reviewed by:</b>	Nelma Arancibia	Senior Project Manager
<b>Revision Amendments:</b>	Updated Work Pack, additional design detail & incorporation/clarification of plan controls, procedures and reporting	
<b>Approval Date:</b>		

# Work Pack

<b>Project:</b>	WSA Bulk Earthworks	<b>Project No.</b>	N81051
<b>Work Pack:</b>	NPE – CSR Water Installation	<b>Doc No.</b>	WSA10-CPBLLBE-01000-CN-WPK-BE-0061
		<b>Rev:</b>	1

## ACTIVITY SCOPE & LOCATION

**Scope of Work:** This Work Pack is for the establishment of the CSR Water Supply to provide water reticulation system around the construction site to various dam locations for the purpose of providing construction water. The system includes >15km of HDPE pipe, several pump stations, truck fill points, automation and ongoing maintenance of the system.

The forecasted site water requirement is approximately 10ML/day, so a sustainable water source needs to be established. CSR have existing reservoirs of water from old Brick pits that they plan on remediating and the combined Volume of water is approximately 1GL. Alternatively, Detention Basin 1 (DB1) has been connected to the Sydney water supply and can store up to 70ML. This has been integrated into the design of the CSR watermain to offer up to 3ML/day.

The system is designed on three pipeline stages with feed pump, and 3 truckfill locations.

- Stage 1 shown as the CSR Brick pit to Kidney dam
- Stage 2 shown as Kidney dam to SP2 discharge point and includes connections to DB1
- Stage 3 shown as Kidney dam to SP3 discharge point and SP34.

Fill points will be installed at three separate locations being Kidney Dam, SP2 and SP3.

The Pipe will be constructed along a CSR Watermain corridor which is 10m wide and goes around the perimeter of Site. This corridor has been elected as having the minimum interaction with the Bulk earthworks design, so the location of the pipeline will not effect other scopes for duration of the project. Ongoing installation will have minor interactions with other work crews due to the relatively small footprint of the required work area (30m x 30m).

Small sections of the pipe will have to be buried or underbored due to the access required by site. Unberbores will be installed at Badgery's Creek and drainage structures will be used where possible for roadway crossings. This Plan has been deisgned so that the pipe predominantly be placed on the surface with thrust blocks holding the pipe secure.

Due to Design and access constraints and forecasted site water requirements, Stage 2 will commence in July 2020, with Stages 1 and 3 following thereafter.

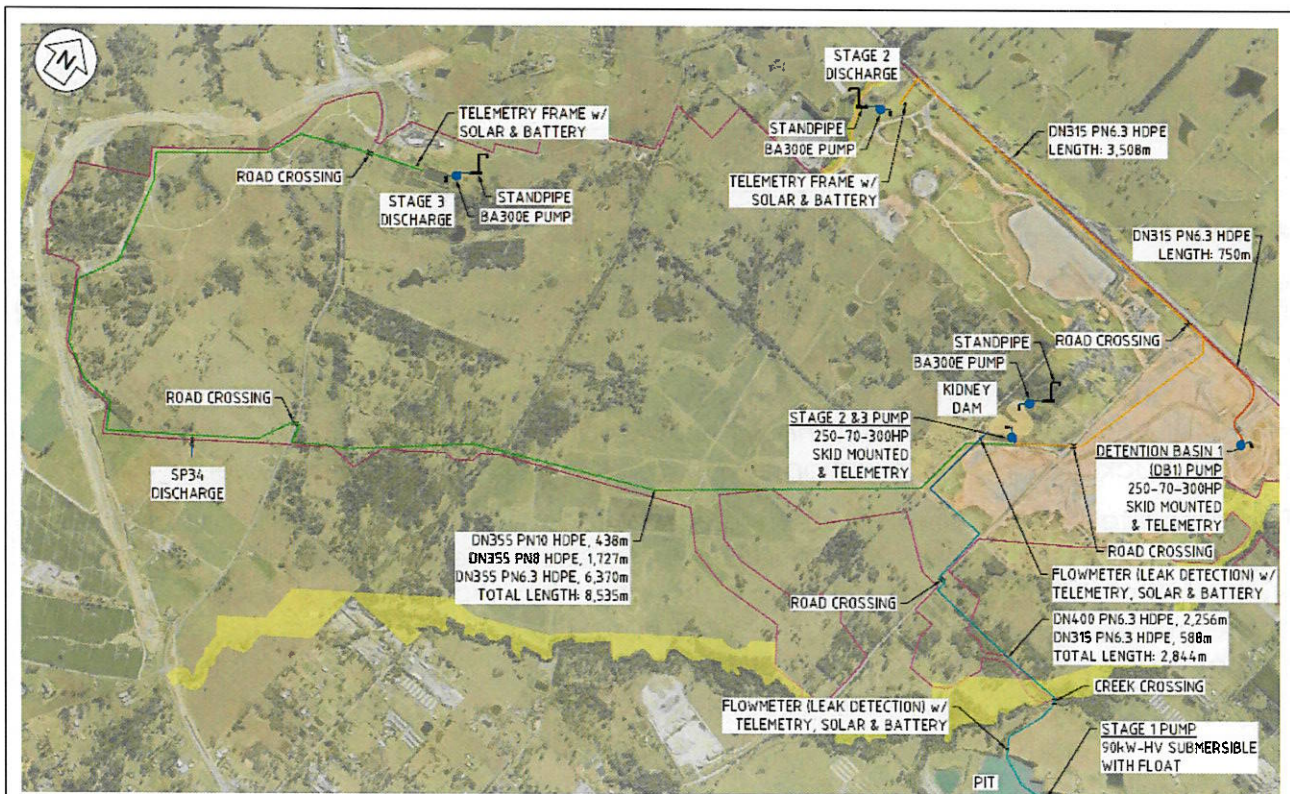

Figure 1 - Site layout Showing the 3 stages of the pipework to be installed (WSA10-CPBLLBE-01000-TW-DRG-000001)

**SCHEDULE**

<b>Start Date:</b>	<b>29/06/20</b>	<b>Planned Completion Date:</b>	<b>31/12/22</b>	<b>Programmed Duration:</b>	<b>3 years</b>
<b>ACTUAL Start Date:</b>	<b>29/06/20</b>	<b>ACTUAL Completion Date:</b>		<b>Actual Duration:</b>	

**COST CODES**

COST TYPE	COST CODE	ELEMENT OF ACTIVITY (ALL or PART)
Subcontractor	10710	Construction Water

# DOCUMENT REVIEW AND APPROVAL

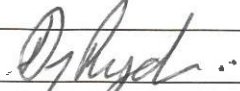
PREPARED BY (Senior Project Engineer and Foreman):				
<b>Acknowledgement that we have consulted with the project's functional managers in the development of this Work Pack.</b>				
<b>Name:</b>	Elizabeth Fensom	<b>Signature:</b>		<b>Date:</b> 19/08/2020
<b>Position:</b>	Senior Project Engineer	<b>Company:</b>	CPBLL JV	
<b>Mobile:</b>				
<b>Name:</b>	Dawson Ryder	<b>Signature:</b>		<b>Date:</b>
<b>Position:</b>	Foreman	<b>Company:</b>	CPBLL JV	
<b>Mobile:</b>	01434073312			

REVIEWED BY (minimum to be Project SHEQ Manager/s)				
<b>Name:</b>		<b>Signature:</b>		<b>Date:</b>
<b>Position Title:</b>				
<b>Name:</b>		<b>Signature:</b>		<b>Date:</b>
<b>Position Title:</b>				
<b>Name:</b>		<b>Signature:</b>		<b>Date:</b>
<b>Position Title:</b>				
<b>Name:</b>		<b>Signature:</b>		<b>Date:</b>
<b>Position Title:</b>				

SUBCONTRACTOR ACKNOWLEDGEMENT (where required)				
<b>Acknowledgement that I have been consulted in the development of this Work Pack and agree to perform works in accordance with this Work Pack.</b>				
<b>Name:</b>	Richard Galloway	<b>Signature:</b>		<b>Date:</b>
<b>Position:</b>		<b>Company:</b>		

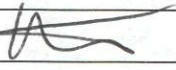
AUTHORISATION / APPROVAL				
<b>Line Manager Approval</b>				
<b>Name:</b>	Ken Edwards	<b>Signature:</b>		<b>Date:</b> 21/8/2020
<b>Project Position Title</b>	Project Manager			



ACCEPTANCE				
<b>Acceptance of Work Pack by Responsible Supervisor in control of works under this Work Pack.</b>				
<b>Name:</b>		<b>Signature:</b>		<b>Date:</b>



**WORK METHOD / SEQUENCING**

The following table should detail step-by-step the tasks required to complete construction activities associated with this Work Pack. A construction program extract / look ahead specific to this Work Pack can be used as a guide when detailing the requirements in a sequential order, i.e. duration of the nominated works, roster, productivity, milestones, etc. All relevant controls identified in the Work Pack risk assessment must be associated with tasks below. Note: Controls nominating reference documents (e.g. ITPs, SWMS, Site Environment Plan/s, Permits, Welding Procedures etc. must be included as attachments to this Work Pack).

Task	Control
<p>1. <b>Site Access And Inductions</b></p> <ul style="list-style-type: none"> <li>• Ensure all persons performing works as detailed under this workpack have completed relevant induction process.</li> <li>• Ensure all persons performing works as detailed under this workpack have had the workpack, SWMS and other relevant safety documentation briefed and have signed on prior to start.</li> <li>• Ensure all plant is on boarded per the 'Manage Mobile Powered Plant Deliveries, Loading and Unloading' process.</li> </ul> <div data-bbox="327 1512 750 1792" style="border: 1px solid black; padding: 5px; margin: 10px 0;"> </div> <p><b>Refer: WSABE-HS-SWMS-0050-Load and Unload</b></p>	<ul style="list-style-type: none"> <li>• All workers to complete Damstra &amp; WSA BE induction</li> <li>• Work pack approved and work teams have been briefed in the requirements detailed under the workpack.</li> <li>• SWMS approved prior to works commencing and all persons performing works have been briefed and have signed onto the relevant SWMS.</li> <li>• VMP to be approved prior to works commencing and issued to site teams.</li> <li>• Contractors issued a copy of WSABE-HS-SWMS-0050-Load and Unload Safe Work Method Statement along with the Western Sydney Airport Bulk Earthworks Chain of Responsibility Plan.</li> <li>• All plant to be assessed against the Plant and Assets Safety Specification Matrix before mobilising to site (ID: MSID-5-637 V6.0).</li> <li>• Asset Inspection Report (ID: MSID-4-948 V1.0) completed and all plant to have been inducted to the site with documentation uploaded to 3D Safety.</li> <li>• All operators/contractors to issue worker competence declaration; WCE – Employer Declaration.</li> <li>• Upon completion of Face to Face WSA BE induction the WCE Supervisor Observation (VOC) is to be completed.</li> </ul> <p><b>As a minimum, Delivery Drivers will be expected to be the holder of the following competencies:</b></p> <ul style="list-style-type: none"> <li>• National certificate of competency for high risk licence to operate plant, where applicable</li> <li>• SOA for mobile powered plant not covered by a National certificate of competency for high risk plant operation</li> <li>• Construction Industry White Card</li> <li>• Completed Employer Declaration from the supplier organisation for the person delivering and unloading the powered mobile plant.</li> </ul>

<p>2.</p>	<p><b>Unloading of plant and equipment</b></p> <p>Works to be Supervised by CPBACCJV:</p> <ul style="list-style-type: none"> <li>• Ensure Designated CPBACCJV loading and unloading supervisor is present.</li> <li>• CPBACCJV plant safety assessor has verified all incoming documents on 3D Safety.</li> <li>• CPBACCJV present Level areas for Loading and unloading of Equipment</li> <li>• Vehicle Management Plan (VMP) is updated by CPBACCJV where required to capture the works from NPE and encapsulate any interactions with other works during the loading/unloading process.</li> <li>• The approved loading and unloading area for mobile powered plant being delivered to the project must meet the below requirements;</li> </ul> <p>Maximum fall 2.9% </p> <p>Maximum fall 2.0% </p> <p>Bearing capacity Min 250 Kpa</p> <p>REFER: WSABE-HS-SWMS-0078-NPE – Working in and around Mobile plant</p>	<p><b>Prestart</b></p> <ul style="list-style-type: none"> <li>• Assess the work site for likely hazards in the area e.g. power lines/services/uneven terrain;</li> <li>• Obtain all relevant and required permits;</li> <li>• Check ground conditions for stability, firmness and grip;</li> <li>• Ensure all unloading areas are within fall guidelines to prevent the unloading machine from tipping or damaging equipment or load;</li> <li>• Use barricading and signage to restrict access to the unloading areas.</li> </ul> <p><b>Moving Delivery Truck to Unloading Sites</b></p> <ul style="list-style-type: none"> <li>• Maintain communication with the truck via radio or positive communication;</li> <li>• Turn on the flashing light to indicate the operations location;</li> <li>• Use the appropriate gearing and drive to the conditions;</li> <li>• Check for pedestrians and other vehicles;</li> <li>• Comply with site or state traffic rules and regulations.</li> </ul> <p><b>Mounting and Dismounting Delivery truck and trailer</b></p> <ul style="list-style-type: none"> <li>• Use three points of contact at all times when mounting and dismounting the vehicle;</li> <li>• Never exit the vehicle without fully applying the park brake;</li> <li>• Ensure there is no oncoming traffic before leaving the cab;</li> <li>• Use a purpose built platform to access trailers. Ensure that suitable controls are in place to ensure that personnel cannot fall from height from trailers</li> </ul> <p><b>Unloading the Truck</b></p> <ul style="list-style-type: none"> <li>• Ensure the equipment is unable to be pushed off the opposite or unloading side, of the trailer whilst unloading.</li> <li>• Leave sections of the load, not being removed, tied down via load binders (only release on the identified item to be unloaded);</li> <li>• Use a spotter when necessary with the use of two-way communication to stop others entering exclusion zone.</li> </ul>
-----------	--	--

		<ul style="list-style-type: none"> <li>• Dogman for rigging should never stand beneath a suspended load.</li> <li>• If the delivery driver is not inducted, they must remain either the truck or a designated waiting area</li> </ul> <p><b>Lifting Equipment and Goods</b></p> <ul style="list-style-type: none"> <li>• If using forks, forks MUST be spread on the forklift/fork equipment carriage and made secure;</li> <li>• Inspect the tynes for damage and wear before using to lift load</li> <li>• Equipment/ loads to be picked up by crane or forked equipment on even ground;</li> <li>• Tag lines are to be used when lifting with a crane.</li> </ul> <p><b>Placing Loads with Telehandler.</b></p> <ul style="list-style-type: none"> <li>• Complete Pre-start of Machine</li> <li>• Drive as close as possible to the unloading place;</li> <li>• Use low gear;</li> <li>• Ensure unloading area is clear from obstacles and personnel before attempting to unload;</li> <li>• Engage park brake;</li> <li>• Engage stabilisers and frame levelling (if required);</li> <li>• Lower the boom slowly;</li> <li>• Ensure the load is stable;</li> <li>• Use spotter with radio or hand signals to direct placement;</li> <li>• Remove the sling;</li> <li>• Disengage the park brake;</li> <li>• Disengage stabilisers and frame leveller (if required);</li> <li>• Check direction of travel is clear;</li> <li>• Slowly reverse the tele-handler from the load;</li> </ul>
3.	<p><b>Ensure all permits have been approved.</b></p> <ul style="list-style-type: none"> <li>• CPBACCJV to issue permits as required by the NPE team.</li> </ul> <p>REFER:</p> <ul style="list-style-type: none"> <li>• WSABE-HS-SWMS-0021- General Earthworks</li> </ul>	<ul style="list-style-type: none"> <li>• Ensure permit to excavate has been approved. Note that Permit to excavate is only required when performing works: <ul style="list-style-type: none"> <li>○ Outside the Construction Impact Zone (CIZ)</li> <li>○ Within 10m of the CIZ Boundary</li> <li>○ Within 10m of installed services inside the CIZ</li> </ul> </li> <li>• Ensure Permit to Perform hot work has been approved.</li> <li>• Ensure Permit to Enter a 'No-Go' Area has been approved</li> <li>• Ensure Land Disturbance Permit is approved and in place.</li> </ul>

4.

#### Lifting and Positioning Pipes with a Telehandler

- NPE to load 20m lengths of PN6.3-10 Pipe into Poly horse in preparation for welding.
- Positioning Poly pipe for Butt welding using the HF350 in areas the T500 cannot access.
- Pipe materials will be unloaded by CPBACCJV and stockpiled in designated areas.
- NPE are responsible for the transport of the pipe lengths from the stockpile to the Polyhorse

#### REFER:

- WSABE-HS-SWMS-0078-NPE – Working in and around Mobile plant



Ensure all controls detailed under Point 2 are referred whilst completing this workpack task

#### Lifting Pipes

- Forks MUST be spread on the carriage and made secure;
- Aim to pick the pipe up in the centre of the pipe length on even ground. On some of the pipe they may be a centre mark on the pipe see symbol below:



- With pipe that has been stockpiled or has been harvested, check to make sure nothing is in the pipe that may unbalance the length;
- When lining up to pick up pipe, line up square to the length of pipe and Use 1st or 2nd gear only;
- Inspect tynes before starting as some tynes are not set level and position tynes level or slightly down;
- When harvesting pipe where multiple lines may be in use you MUST use a spotter to ensure other lines are not damaged;
- When lifting large diameter pipe or multiple lengths, you need to check the load chart to ensure the Telehandler can safely lift the load, also take into account if you need to turn with the load in the air;
- When carrying pipe ensure there is no pipe over hanging the tips of the tynes.
- Operator is to walk the path first to ensure ground conditions are suitable.
- RGBY System to be used to indicate for tagging and testing of all lifting equipment

#### Loading Pipe

- Ensure area where pipe is being placed is clear of obstructions that may damage pipe;
- If pipe is being stockpiled inspect area for obstructions, cone off area, use a spotter if required;
- DO NOT have short lengths hiding in with longer lengths. When pipe is being picked up the shorter lengths may unbalance the load;
- Position wheels straight when lowering boom back in to decrease chances of tipping forwards;
- When stockpiling pipe for later use, take into account how pipe will be moved later. (E.g. how will it be loaded on a pipe truck?)

### **Carrying Pipe**

- Check pathway before travelling and look for overhead power lines, trees or any other obstructions that may hinder the pipe and yourself;
- Make sure that your travel surface is even, use a spotter if required;
- Have tynes level or slightly tilted back never fully back or down;
- If travelling over long distances through confined areas, or areas of heavy traffic a pipe truck may be required;
- Do not stick a tyne in the end of the pipe to tow it over any distance;
- If a pipe can only be moved by towing a chain or sling must be secured onto the pipe through a lifting eye or shackle only.

### **Placing Loads**

- Drive as close as possible to the unloading place;
- Ensure unloading area is clear from obstacles and personnel before attempting to unload;
- Place load over the unloading area. Engage park brake and engage stabilisers and frame levelling (if required);
- Lower the boom slowly and ensure the load is stable;
- Use spotter with radio or hand signals to direct placement;
- Disengage the park brake and disengage stabilisers and frame leveller (if required);
- Check direction of travel is clear and slowly reverse the Telehandler from the load;
- If the sling should move when a lift is in progress lower to the ground quickly and safely and re-sling the load.

5.

**Install 315-400mm Pipe using a TracStar 500 Welder and HF350 Welding Unit**

- T500 and HF350 welders to be used in conjunction with polyhorse and telehandler.
- The polyhorse lines up the pipe ready for loading into the T500. This reduces manual handling and working around mobile plant.
- Mechanical lifting used to lift pipe into position on HF350. HF350 to be used in areas not accessible by T500 welding unit.

**REFER:**

- WSABE-HS-SWMS-0078-NPE – Working in and around Mobile plant
- WSABE-HS-SWMS-0079-NPE – Installing HDPE Pipe and Fittings



TracStar 500 (T500)

**Loading and Unloading TracStar 500 (T500) Welder and HF350 Welding Unit**

- Maintain smooth and even operations of the controls throughout the task and at all times use a spotter;
- All tracked machines become extremely unstable at the apex of the ramps, all care must be taken when balancing on this pivot point;
- If it is not safe to load/unload the Track Star 500 welder by the ramps onto the trailer, you should utilise a crane to load/unload
- Ensure to use correct and in date lifting/rigging equipment for lifting the Track Star 500 welder;
- Ensure CPBACCJV Pre-lift Start Card is completed prior to any lift.

**Set up welding area**

- Complete inspection of welding machine (in accordance with the relevant pre-start checklists). This checklist must be documented and handed in to your Supervisor;
- Ensure that the electrical inspection tags are current on all electrical leads.
- Notify relevant personnel of the commencement of works in accordance with site procedures and client requirements;
- Obtain any permits to work as required for site procedures and client expectations;
- Familiarise yourself with area, prior to commencing work (e.g. CPBACCJV Task Card);
- Barricade the work area with witches hats and install warning signs. If welding on a haul-road, ensure that traffic management has been implemented;
- Refer to CPBACCJV Barrier Selection Guide
- Beacons and hazard lights to be used as required (particularly when working around moving mobile equipment and vehicles);
- When setting up the welder ensure that heater plate is placed in a safe and accessible area out of the way of traffic that may be moving in area.

**Loading Pipe into TracStar 500 & HF350**

*Ensure all controls detailed under Point 4 are referred whilst completing this workpack task*

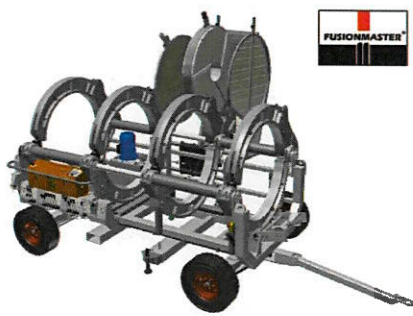

HF350 Butt Welding Unit

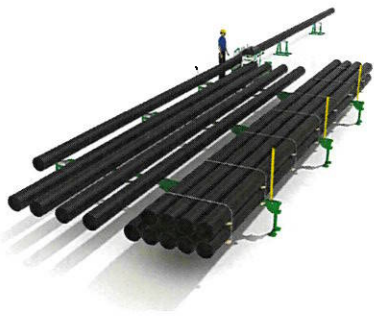

PolyHorse



Loading Pipe into Track star

- Make sure there are no Hazards in the way of the TracStar 500 welder before you move it in to position;
- This should be setup on level and stable ground if possible, to reduce any inadvertent movement which might damage the equipment;
- Ensure heater plate is on the ground after T500 is in position and as close to the T500 as is safe to enable machine to load pipe without the risk of the heater plate being struck by the machine or the pipe;
- Then proceed with the loading being observant at all times for hazards;
- The loading of the TracStar will be by mechanical means e.g. telehandler, integrated tool carrier (I.T.) etc.
- Only ticketed and competent operators are permitted to operate the TracStar 500;
- Pipe supports MUST be installed either side of the welder. Ensure that they are wide enough to support the pipe, you can use additional pipe if necessary;
- With all the pipe stands you must use mechanical means to lift and reposition the stands. If you pull or drag out the stands by hand you could injure yourself;
- Have the operator lift the pipe so the TracStar 500 can tram into position. Then lower pipe into the clamps;
- The operator will lift the second section of pipe into position and lower with poly welder's instructions, and tram into final position ready for welding;
- Once the welding has been completed the operator with the instructions from the welder will lift one end of the pipe to allow the TracStar 500 to tram down the pipe the next position;
- When pipe has been lifted the TracStar 500 will move the rollers in to tramming position and proceed down the pipe;
- Once in position the operator will lower the pipe back on to the TracStar 500 welder;
- Under instructions from the welder operator the operator will pick up and position the next section of pipe with clear signals from welder operator and the use of a third person to cover the blind spots caused by the boom if required;
- Place pipe into position in the TracStar 500 welder with the instructions from the welder operator only. The operator must not make any moves unless directed by the poly welder;
- All employees will keep to the side of the pipe while it is elevated in the air. At no time shall a worker

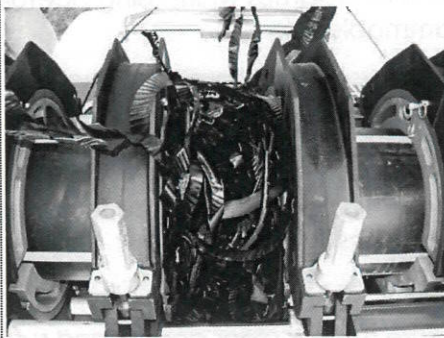

Swarf Buildup in machine

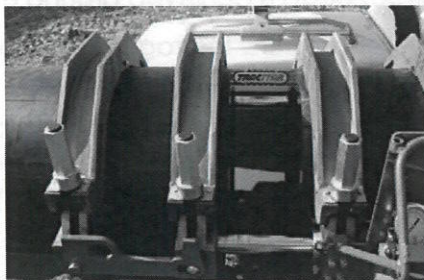

Clean Pipe ends

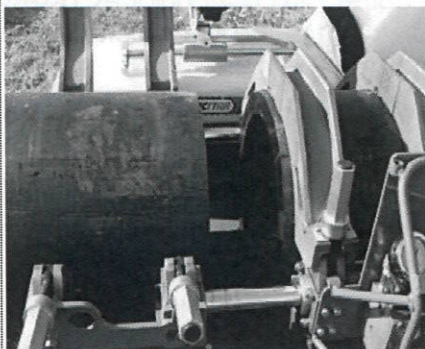

Clean Pipe Faces

position themselves beneath a pipe while it is suspended.

- Housekeeping for the TracStar 500 - any swarf build up on the machine MUST only be removed under the direct orders of the Polywelder in charge of the machine;
- Ensure the heater plate is positioned as close to the welding machine as possible to remove it from the line of fire of both the pipe and the machine loading the pipe.

#### Face Pipe Ends

- Welding in wet weather is not permitted;
- IP56 plugs are mandatory on all leads and Extension leads must be screened;
- Welder IP56 leads must have mechanical protection in situ;
- Ensure that RCD protection on the power source is in place;
- Hands must be kept clear of rotating blades and no loose clothing to be worn;
- Remove all poly pipe shavings to minimise environmental impact and to ensure the work area is kept neat and tidy;
- Alignment of the poly pipe MUST be checked before you start the welding process. Maximum allowable misalignment of pipe is 10% of pipe wall thickness;
- Do not over pressurise the facer (1500kPa max over drag pressure);
- Ensure that the drill speed is set to low whilst in operation;
- Increase pressure using hydraulic hand pump until Shaver begins Facing the pipe. Maintain even pressure until complete ribbons of swarf are observed coming from pipe faces;

#### Clean Pipe Faces

- Pipe edges can be sharp and cause injuries to the hands and forearms. Ensure cut 5 gloves are worn as a minimum project requirement;
- Prior to cleaning the pipe face, check whether other personnel are working on the same pipeline. Other personnel can move the pipe causing a crush injury to the hands whilst the faces are being cleaned;
- Ensure that dust creation is as minimal as possible and implement dust suppression/dust avoidance where necessary;



- No naked flames whilst using acetone – it is highly flammable.
- Ensure use of contaminant free rags/wipes;
- Check pipe faces after wiping and re-clean if traces of dirt or contaminants remain;
- Clean heater plate surface following the same guidelines.

#### **Heating Phase**

- Ensure there is clear access and sufficient room to place and remove the heater plate. Ensure that you will not cause injury to other personnel by contacting them with the hot heater plate;
- Ensure to check the temperature on both sides of the heater plate. Use a temperature gun and record the temperatures of both sides of the heater plate
- Apply welding pressure as pre-determined by Parameter Card for pipe size and machine type until correct bead is achieved around entire pipe;
- Release pressure to drag pressure and start Soak time;
- Once soak time is complete open carriage, remove heater plate and close pipe faces with even pressure until weld pressure is achieved;
- Maintain pressure until pressure loss ceases then lock pressure by closing pressure release knob and start cool down time;
- If working off the back of the vehicle you MUST make sure that the side panels are down at all times;
- Ensure the face of the pipe and heater plate is clean prior to installing the heater plate (Heater plate – 220°C).

#### **Pipe Removal from Polywelding machine**

- Use correct lifting techniques; assess the size, shape and weight of the lift and employ safe manual handling practices.
- Use mechanical means such as a telehandler, Bobcat or Crane to unload pipe as required;
- Ensure pipe is removed in a manner that prevents damage to the polywelding machine and injury to personnel;
- The pipe can move when loosened in the clamps. Ensure that all personnel in the working area are clear of potential crush zones, including other personnel working on the same pipeline;
- Do not walk under elevated pipe being raised by a machine. Serious injury may occur if the pipe falls.

		<p><b>Move Polywelding Machine to next Weld</b></p> <ul style="list-style-type: none"> <li>• Use mechanical means to lift/shift the welding machine;</li> <li>• Be aware of traffic and mobile equipment operating in the area. Obey all road rules and lower speeds whilst operating mobile equipment to ensure that injury and equipment damage does not occur;</li> <li>• When passing stationary mobile equipment without clear vision (i.e. telehandler has a blind spot), sound your horn twice to ensure that personnel in the work area are aware of your presence. Positive communications must be made before proceeding.</li> <li>• Machine must be lifted with forks under the carriage or lifting chains attached to the lifting points;</li> <li>• When moving the welder ensure that the heater plate is placed onto the welding machine in a safe stable position that will enable the heater plate to be moved with the welder and not have to be unplugged to maintain heat.</li> </ul>
<p>6.</p>	<p><b>Installing Butterfly Valves, Air release Valves and Check Valves</b></p> <ul style="list-style-type: none"> <li>• NPE to install Butterfly valves at various sections on the pipeline to move water between the basins.</li> <li>• Each Connection must have its own Installation sheet that shows the installation was completed as per design requirements.</li> <li>• Connection installation must be completed using calibrated Torque Wrench</li> </ul> <p>REFER</p> <ul style="list-style-type: none"> <li>• WSABE-HS-SWMS-0079- Installing HDPE Pipe and Fittings</li> <li>• WSABE-HS-SWMS-0080- Maintenance works for HDPE Pipe</li> </ul>	<p><b>Installation Sheet</b></p> <ul style="list-style-type: none"> <li>• A 'Bolted Joint Installation Sheet" must be completed for the installation of every butterfly valve.</li> <li>• The valve numbering should be indicated on the drawing provided to the installation contractor. The number that uniquely identifies the valve on the drawing must be used on the installation sheet and written on or next to the valve to enable the specifications to be correlated.</li> </ul> <p><b>Torque Wrench Calibration</b></p> <ul style="list-style-type: none"> <li>• Torque wrenches are to be individually numbered and calibrated periodically as per the manufacturers' recommendations or every four months.</li> <li>• A report that specifies the inaccuracy of the wrench prior to calibration is to be provided by the person or organization conducting the torque wrench calibration. This is to enable any joints that require retightening to be easily identified via the installation sheets in the event that the wrench was deemed to be unacceptably inaccurate prior to recalibration.</li> <li>• This report will indicate the number of the most recent joints that need to be retightened</li> </ul>

### Installation Procedure for Butterfly Valves

- Create a new Installation Sheet for the new valve installation.
- Fill out all details in the top section of the installation sheet regarding the valve numbering while in the vicinity of the valve. This includes the unique number, location/functional description (e.g. Isolation Valve on Brampton Saline Line near BRP82) and GPS co-ordinates if possible.
- Fill out the details regarding the specification of the valve connection including size while independently referring to this document and determining the correct torque settings for the size of the valve as per tables
- Write the valve number and valve torque setting on the pipe next to the valve, such that it is sufficiently identified.
- Visually examine and clean the stub flanges, bolts, nuts, valve spacer and valve seating surfaces. If any of the components are deemed to be in an unsuitable condition, they are to be removed and replaced. This is at the discretion of the CPBACCJV.
- Gaskets may need to be installed if the faces of the valve spacers and Stub Flanges have scratches or damage to them.
- The correct size bolts must be used at all times. Common soft metal flat washers are not to be used under any circumstance. Through- hardened heat treated washers are to be used. If these are not available, the valve may be installed without washers after consultation with the Field or Project Engineer.
- Move the valve and valve spacers (if required) into position between the stub flanges.
- Liberally lubricate bolt threads, nut threads, and backing ring surface under the nut. Insert the bolts and connect the nuts. Bolts are to be installed with the Nut Ends facing the direction of flow.
- Write the numbers on the bolt heads in a circumferential sequence stating at 12:00 position in a clockwise direction.
- Check the flange, valve and valve spacer surface alignment, concentricity, angularity and gap for acceptability.
- To connect the flange, valve and valve spacer faces squarely together, hand tighten, then pre-tighten all bolts as per the proper sequence to approximately 15-25 Nm torque while not exceeding 20% of the target torque.

- Re-check any stub flange face gap and backing ring gap for uniformity. Check the backing ring gap around the flange circumference between each of these rounds, measured at every other bolt. If any gap is not reasonably uniform around the circumference, make the appropriate adjustments by selective bolt tightening before proceeding.
- Tighten bolts as per the tightening sequence provided in Table 2 of Section 5, with the torque settings provided in Table 1 of Section 4 and as specified on the installation sheet. For valves of diameters 450mm or less, the first round will be to 30% of the target torque and the second round to 60% of the target torque. The third and final round will be to the target torque. For valves of diameters 500mm or above, the first round will be to 25% of the target torque, second to 50% of the target torque, third to 75% of the target torque and final round will be to the target torque.
- A final 'check' round is conducted at the target torque.
- A small straight line is to be marked in a vertical orientation on the backing ring surface above each bolt head.
- Fill out the 'Time Installed' and 'Date Installed' sections of the installation sheet.
- Wait 4 to 24 hours and re-torque to the target torque value using one or two sequence-rounds, followed by one rotational round at the target torque value.
- A second small straight line is to be marked on the bolt head in the same orientation as the first line. This is to help identify which bolts have been retightened and whether any bolts have become loose over time.
- Fill out the 'Time Retightened' and 'Date Retightened' sections of the installation sheet. Tick the box on the installation sheet verifying that this procedure has been followed for the installation of the valve. Sign the installation sheet and provide a hard copy to the construction supervisor.

**For Tables referring to Torque, tightening Sequences and Bolt Sizes, refer to the Appendices Section of this work pack.**

7.

### Install Thrust Blocks Using Excavator

- NPE to install Thrust Blocks every 50m as per temporary works design.
- 3M3 of material to be placed and compacted every 50m on top of pipe

#### REFER:

- WSABE-HS-SWMS-0021- General Earthworks
- WSABE-HS-SWMS-0078- Working in and Around Mobile Plant

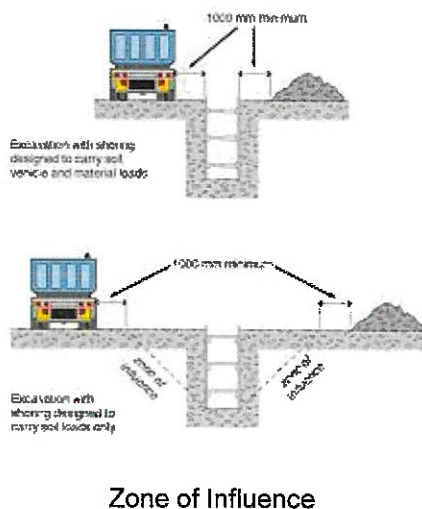

### General Safety Instructions

- Read the manufacturers operation manual;
- Refer to relevant codes of practice or standards in the relevant jurisdiction regarding excavator use (Safe Work Australia – Excavation code of practice, model work health and safety Act and Regulations)
- Do not operate equipment near pedestrians or people;
- Do not operate the machine under the influence of drugs or alcohol. Ensure that you are fit for work.
- Complete pre-start checklist prior to shift operation;
- Report any equipment faults or damage to the applicable NPE Supervisor, Manager or CPBACCJV Supervisor.
- Refuelling - Do not smoke, or introduce ignition source, always turn engine off and allow engine to cool first, relieve fuel pressure by loosening cap slowly, wipe clean any fuel spills prior to re-start, if fuel spilled on clothes change clothes, ensure cap is replaced & store fuel vessel away from work area;
- Do not breathe fuel vapour & replace cap securely after fuelling;
- Do not operate engine without adequate ventilation;
- Beware of hot surfaces on engine & other parts;
- Obey Danger, Warning and Caution labels on the machine.

### Digging Safely

- Always contact and gain authority from the relevant site owner prior to any excavation work. This is imperative prior to performing any digging to identify any existing underground services, sensitive environmental areas, traffic moving in the area, overhead power line positions and potential for isolation or removal and any other relevant hazards;
- Do not dig deeper than 1.5m without shoring or benching.
- Ensure that The zone of influence on excavations is barricaded off to ensure people and plant do not enter. Zone of Influence is Depth of Excavation plus 1.0m on both sides.
- Beware of oxygen deficiencies and gas build up in pits and holes.

### General Excavator Operating Instructions

- Ensure that applicable signage, exclusion zones, hard barriers, cones and other required controls are

		<p>implemented prior to operation; refer to CPBACCJV Barrier Selection Guide.</p> <ul style="list-style-type: none"> <li>• Ensure that a traffic management plan has been implemented where required;</li> <li>• Ensure that a spotter/s is always utilised whenever operating the machine;</li> <li>• Positive communication must always be utilised between the operator of the excavator, the spotter and any other applicable person's in the location of operation;</li> <li>• All operators must be trained and hold appropriate certification or licence as well as having been VOC'd</li> <li>• Always wear a seat belt;</li> <li>• Ensure ground conditions will support the machine and load;</li> <li>• Never operate the machine near overhead power lines;</li> <li>• Do not operate near ledges or near locations where the equipment can become unstable (zone of Influence);</li> <li>• Do not allow persons within the excavator slew area. The spotter must stay out of this area unless the excavator bucket has been grounded and they have permission to enter the area via positive communication;</li> <li>• Keep all parts of body within the frame of the excavator, whilst operating, at all times;</li> <li>• Always ensure that the operator is seated with seat belt fastened prior to starting;</li> <li>• Bring the machine to a stop before shifting controls;</li> <li>• Ensure that the lock lever is in the lock position when starting. Ensure you test the emergency stop before starting;</li> <li>• Remember If the swing frame has been turned 180 deg the travel directions will be in reverse;</li> <li>• Always ensure the cab type machines have an emergency hammer/pick on board for breaking glass in case of danger;</li> <li>• Never operate or start the machine from outside the cab or seat as you could move the controls the wrong way and cause serious injury;</li> <li>• Ensure adequate clearance for full swing of machine;</li> <li>• Ensure all mirrors in place prior to operation;</li> <li>• Sound horn before moving and when turning;</li> </ul>
--	--	--

		<ul style="list-style-type: none"> <li>• Always check clearances before driving under objects;</li> <li>• Never carry additional persons;</li> <li>• Do not jump on or off the machine at any time as this can cause injury;</li> <li>• Avoid turning engine off or applying park brake when moving as machine could stop abruptly causing load to shift or fall;</li> <li>• Always park on flat level ground and engage park brake</li> <li>• Always stop the engine before removing or changing equipment or attachments &amp; release hydraulic pressure (see manual);</li> <li>• Do not service, attempt to repair or modify machine unless competent, authorised and without engine off and parked with keys removed;</li> <li>• If the machine tips – do not jump, brace yourself, stay in the cab, keep seatbelt fastened, hold on and lean away from point of contact</li> </ul>
8.	<p><b>Installing Pipework on and around water</b></p> <ul style="list-style-type: none"> <li>• Connection to Detention Basin 1 requires Pipe to be installed on water or in channels which may fill with water</li> <li>• Installing Sections of Stage 1 requires an Underbore of Badgery's creek (see underbore section for further details)</li> <li>• Approximately 400m of pipe to be installed on the CSR Pit to connect to the Pontoon Pump.</li> </ul> <p><b>REFER</b></p> <ul style="list-style-type: none"> <li>• WSABE-HS-SWMS-0077- Working over or Around Water</li> </ul>	<p><b>Working over or around water at NPE can include but not limited to:</b></p> <ul style="list-style-type: none"> <li>• Working on the banks or shore of a water body.</li> <li>• Working on a fixed platform on any body of water</li> <li>• Working on the edges or inclines of lined dams.</li> </ul> <p><b>Planning for the task</b></p> <ul style="list-style-type: none"> <li>• Adequate provisions, including clothing type, sun protection, food and water requirements;</li> <li>• An assessment of the water is undertaken and a water sample is analysed if required;</li> <li>• Check that the work will be completed during daylight hours;</li> <li>• Permission is given to enter the specific location;</li> <li>• There is a minimum of 2 competent personnel undertaking the task;</li> <li>• All relevant team members have communicated that they are capable of swimming and are competent to undertake the task</li> <li>• Personnel who may be exposed to the potential of drowning must be able to competently swim or utilise a PFD (Personal Flotation Device – Self Inflatable (life vest)) which they have been trained to use;</li> <li>• Inflatable PFD's must comply with the same standards for foam PFD's. They must be gas inflated and not rely on oral inflation only. Inflatable PFD's</li> </ul>

		<p>are also required to have markings that show the level of buoyancy that the PFD will provide.</p> <ul style="list-style-type: none"> <li>• Separation controls must be used where possible and appropriate, including barricades or guarding;</li> <li>• One person involved in the task (who will be able to assist in an incident as per the emergency rescue plan) must hold a minimum of a current senior first aid certificate, or there must be immediate access to emergency response or first aid personnel.</li> </ul>
9.	<p><b>Underboring Badgery's Creek for Crossing</b></p> <ul style="list-style-type: none"> <li>• Underbore of approximately 70m to be completed by NPE for crossing of Badgery's creek.</li> <li>• The diameter (OD) of the pipe through the underbore will be 400mm</li> <li>• NPE to Finalise Subcontractor information (AV Drilling) for the completion of this task</li> <li>• Additional underbore may be required at Badgery's creek road between the Creek underbore and the Kidney Basin</li> </ul> <p><b>REFER</b></p> <ul style="list-style-type: none"> <li>• WSABE-HS-SWMS-0081- Underboring works</li> <li>• WSABE-HS-SWMS-0078- Working in and Around Mobile Plant</li> </ul>	<p><b>Site Establishment</b></p> <ul style="list-style-type: none"> <li>• The under-bore is proposed to set up in the paddock beside the creek.</li> <li>• Carry out any necessary inductions and/or tool-box meetings to ensure all personnel are fully aware of the scope and sensitivities of the project.</li> <li>• Pothole all services that may be within the bore location to determine their depth. The design is subject to change slightly once the all services have been located.</li> <li>• Establish the site compound including silt mesh and fencing as required.</li> <li>• Excavate launch pits at the proposed location for collection of drilling fluid.</li> <li>• Ensure Design of Launch and Exit Pit suit the requirements of the underboring machine.</li> <li>• Manoeuvre drill rig and ancillary equipment into correct position and set up all safety and environmental requirements including strike alert system.</li> </ul> <p><b>Pilot Bore</b></p> <ul style="list-style-type: none"> <li>• The pilot bore will be approximately 100mm in diameter. The drilling rig and equipment will be set up and operated from the entry side.</li> <li>• Confirm drilling fluid plan for the expected ground conditions, Mix appropriate drill additives in a mix system.</li> <li>• Select appropriate drill head. Install guidance equipment into drill head and calibrate.</li> <li>• Proceed with pilot hole.</li> <li>• The location of the drill head is to be constantly checked as every new rod is added to the drill string. Data from the locations is collected and recorded on bore-logs and assessed against pre planned profile. Adjustments are made to correct the path if required.</li> <li>• Excavate exit pit at the appropriate location and drill into pit.</li> </ul>





Typical Underboring Setup

- The drilling fluid will flow back to the entry pit where it may be pumped to the recycling unit on-site which will be removed by Vacuum Truck for disposal.

#### Reaming

- Once the pilot bore is achieved the borehole will be reamed to the required size (470mm). The HDD Contractor may complete the borehole resizing by forward reaming or back reaming.
- The reaming process will then comprise of swabbing passes as required to ensure the borehole is well cleaned. Based on the ground conditions, the crew will use appropriate reamers for the conditions.
- Once the pilot bore has been established the back reamer will be attached to the rods within the exit pit. Reaming will progress from the exit pit back to the rig and entry pit for back reaming or from the entry pit to the exit pit for forward reaming. Several different size reamers may be used in a staged reaming process to reach the required under-bore diameter. Once the 470mm ream is complete the reamer will be pushed back through the borehole.
- The drilling fluid program for reaming may be changed depending on the feedback gained from the pilot bore. During the reaming operation the drilling fluid plan will require constant monitoring on the mud viscosity and return volume to ensure no frac outs occur.
- All drill fluid and cutting returns will flow back to the entry or exit pit where they will be pumped to the vacuum truck for disposal. Note: as the hole diameter increases so does the volume of drilling fluid to facilitate the suspension of the increased volume of cuttings.

#### Pipe Welding and Pipe installation

- The pipe will be stored and welded on site in one string. This will allow pipe to be installed with no stops for welding.
- The 70m 1x 400mm conduit will be butt fusion welded into the required length. The pipe will be strung out directly behind the exit to prevent damage to the pipe and reduce pull back pressures.
- A lead in trench will be excavated from surface level down into the exit pit to allow connection of the pulling head to the pipe pulling assembly at the end of the drill rods. The pipe will be pulled through the borehole once the pulling head is connected to the drill rods. During the operation the pull-back pressure, fluid returns, mud weights, and downhole

		pressure will be constantly monitored for uplift and frac-outs.
10.	<p><b>Launching and Retrieving Pontoon Pump</b></p> <ul style="list-style-type: none"> <li>• NPE to Install Pump on CSR pit as part of stage 1 of the CSR Watermain.</li> <li>• 90kW-HV Pump to be installed on a pontoon which will be lifted and pushed onto the water using excavators and dozers</li> <li>• Connection Design to the power supply to be finalised.</li> <li>• Access to CSR pit to be organised through CSR and WSA once stage 1 has design approval.</li> </ul> <p>REFER</p> <ul style="list-style-type: none"> <li>• WSABE-HS-SWMS-0077- Working over or Around Water</li> <li>• WSABE-HS-SWMS-0078- Working in and Around Mobile Plant</li> </ul>	<p>Ensure all controls detailed under Point 7 are referred whilst completing this workpack task</p> <p><b>Pushing Pontoon onto a Water Body</b></p> <ul style="list-style-type: none"> <li>• Ensure CPBACCJV Task card is completed at the start of every shift and the task card is reviewed after every change in work or break.</li> <li>• Restrict access to work area. Authorised personnel only. Use signage and positive communications;</li> <li>• Secure pumps and engines to pontoon with appropriate fasteners. Secure pipework and electrical cable where appropriate;</li> <li>• Ensure that towing sling / drag chain has been inspected for damage and has also been tagged where required;</li> <li>• Attach appropriate towing sling / chain from Excavator or dozer to pontoon, slowly take up strain by moving dozer forward. Always tow pump set over hard ground and in a straight line, do not make sharp turns or side pull. Tow to final launching area;</li> <li>• Relocate towing sling / drag chain to the opposite side of the pontoon and secure to blade of the excavator or dozer, this will eliminate uncontrolled movement in areas of steep gradient;</li> <li>• Push pontoon slowly to the edge of the body of water;</li> <li>• Utilise ropes tied to the pontoon for control once it is pushed into the water. These can be used by personnel to position the pontoon as it floats out to its desired location;</li> <li>• Ensure competent personnel are located on the water in boat keeping a safe distance from the pontoon. (refer site specific exclusion zones);</li> <li>• Remove sling from excavator/dozer and pontoon;</li> <li>• Gently push pontoon onto the water;</li> <li>• Add pipework and attach cable where appropriate;</li> <li>• Do not enter exclusion zone until positive communication has been made and Excavator or dozer is fully clear of the work area.</li> </ul> <p><b>Pushing pontoon pump into position using a boat</b></p> <ul style="list-style-type: none"> <li>• Place spotter onto the pontoon to guide the boat operator into position using positive communication;</li> </ul>

		<ul style="list-style-type: none"> <li>• Gently nudge the pontoon using the bow of the boat using constant pressure to keep the momentum of the pontoon;</li> <li>• Use ropes from the banks of the water as discussed earlier;</li> <li>• When in place secure the pontoon with the appropriate anchoring system;</li> <li>• Remove tie down chains securing the pump to the pontoon;</li> <li>• The spotter will then access the boat to return to the access ramp.</li> </ul> <p><b>Retrieval of pontoon pump</b></p> <ul style="list-style-type: none"> <li>• Retrieve pontoon anchoring system;</li> <li>• Place spotter onto the pontoon to guide the boat operator into position using positive communication;</li> <li>• Gently nudge the pontoon towards the access ramp using the bow of the boat, using constant pressure to keep the momentum of the pontoon;</li> <li>• Remove pipework and cable as the pontoon is pushed into the ramp;</li> <li>• Attach appropriate sling to the tow points on the pontoon and the dozer;</li> <li>• Gently tow pontoon from the body of water.</li> </ul>
11.	<p><b>Installation of Standpipes</b></p> <ul style="list-style-type: none"> <li>• Standpipes to be installed at Kidney Basin, T18 and T5 as fill points for watercarts</li> <li>• Remotely activated pumps to be connected to each standpipe.</li> </ul> <p>REFER</p> <ul style="list-style-type: none"> <li>• WSABE-HS-SWMS-0077 - Working over or Around Water</li> <li>• WSABE-HS-SWMS-0078- Working in and Around Mobile Plant</li> <li>• WSABE-HS-SWMS-0079- Installing HDPE Pipe and Fittings.</li> </ul>	<p><i>Ensure all controls detailed under Point 5 and point 8 are referred whilst completing this workpack task</i></p> <p><b>Installing the standpipe</b></p> <ul style="list-style-type: none"> <li>• Ensure a flat and level pad is constructed for the standpipe to be erected onto;</li> <li>• Construct an adjacent level pad for the BA300E pump.</li> <li>• Correct lifting gear to be used during the unloading process of the pump and standpipe. Both the pump and the standpipe can be unloaded using an IT loader or using the approved lifting points;</li> <li>• Follow the assembly instructions for the installation of the standpipe located in the Appendices section of this workpack</li> <li>• Complete pre lift start card and task card for the works involved in assembly of the standpipe.</li> <li>• Ensure the ground conditions are suitable for lifting as the standpipes are installed close to a water body.</li> <li>• Once the standpipe has been erected, connect the BA300E pump to the standpipe using the 315mm PN6.3 Pipe.</li> </ul>

<p>12.</p>	<p><b>Interaction with CSR – East of Badgery’s Creek (outside ECM and CIZ boundaries)</b></p> <ul style="list-style-type: none"> <li>• Work to be completed on CSR owned land.</li> <li>• There are tenants on the land with livestock for grazing;</li> <li>• Access to be constructed using imported sandstone</li> <li>• Ongoing works by CSR watermain subcontractor (NPE)</li> </ul> <p>REFER</p> <ul style="list-style-type: none"> <li>• WSABE-HS-SWMS-0077 - Working over or Around Water</li> <li>• WSABE-HS-SWMS-0078- Working in and Around Mobile Plant</li> <li>• WSABE-HS-SWMS-0021- General Earthworks</li> <li>• WSABE-HS-SWMS-0083- Underboring works</li> </ul>	<p><b>Access to CSR Land</b></p> <ul style="list-style-type: none"> <li>• Ensure appropriate permits have been obtained from both WSA and CSR – permit to work.</li> <li>• Complete a site inspection with CSR. <ul style="list-style-type: none"> <li>○ Record any already damaged areas, existing structures and landmarks that may be affected by CSR watermain construction or temporary access track construction.</li> <li>○ Complete handover with CSR.</li> </ul> </li> <li>• Refer to CSR Access Plan in the Appendices Section of this workpack.</li> <li>• Complete regular inspections of the CSR Land to ensure ground conditions do not significantly change due to rain events, works completed by landowners or works completed by residents/tenants.</li> <li>• Alter the access to the eastern end of the Badgery’s Creek underbore as required to suit changing ground conditions and to minimise impact on residents/tenants.</li> </ul> <p><b>Mobilization on CSR Land</b></p> <ul style="list-style-type: none"> <li>• Provide adequate notice to CSR and Residents of planned works. <ul style="list-style-type: none"> <li>○ Major works such as import of sandstone and float in of plant and materials: &gt;2 weeks’ notice;</li> <li>○ Minor works such as subcontractor access and inspection of equipment &gt;48 hours’ notice;</li> </ul> </li> <li>• Area is inspected by supervisors and safety team prior to ensure all deliveries can be unloaded safely and with minimal impact to surrounding residents;</li> <li>• Ensure sandstone deliveries via truck and dogs are recorded and unloaded safely. Tipping of must be performed on a flat area &lt;3% grade. Survey is to verify grade of the tipping off area;</li> <li>• Ensure plant floats are managed and observed by appropriate members of the safety team as per Section 2 of this workpack;</li> </ul>
------------	---	---

#### **Installation of temporary access track on CSR Land**

- Access tracks to be installed as per CSR Access plan in the appendices section of this workpack;
- Ensure Permit to excavate is completed for all works outside the CIZ;
- Material used is to be imported sandstone placed directly over the topsoil. Topsoil is to be preserved where possible;
- Install marker layer after first 100-150mm of sandstone to indicate proximity to topsoil. This is so the deconstruction of the haul road can be completed with minimal impact to the underlying topsoil;
- Work areas are to be clearly delineated;
  - Flagging signage to be installed and maintained to clearly identify tip-off areas, pedestrian access and LV parking/access;
  - ATF Fencing to be installed to separate residents and plant;
  - Bunding to be installed to separate Light vehicles and heavy plant.

#### **Demobilisation Deconstruction of Temporary access track**

- Ensure Permit to excavate is completed for all works outside the CIZ;
- Excavate Access track down to the marker layer. Take precaution when excavating past the marker layer so as to create minimal disturbance of the natural ground;
- Once the temporary access track has been removed, complete a site inspection with CSR;
  - Refer to initial site inspection and verify any changes to the area that are a result of CSR watermain construction or temporary access track construction;
  - Complete handover back to CSR.

<p>13.</p>	<p><b>Establish Local ERSED Controls</b></p> <ul style="list-style-type: none"> <li>• ERSED controls are to established by CPBACC prior to commencement of CSR Watermain Construction</li> <li>• CSR pipe subcontractor (NPE) is responsible for maintaining ERSED controls.</li> </ul> <p>REFER</p> <ul style="list-style-type: none"> <li>• WSABE-HS-SWMS-0077 - Working over or Around Water</li> <li>• WSABE-HS-SWMS-0021 - General Earthworks</li> <li>• WSABE-HS-SWMS-0083 - Underboring works</li> </ul>	<p><b>Site Establishment</b></p> <ul style="list-style-type: none"> <li>• Ensure permit to work is obtained of working near or outside the CIZ or within ECM Zones.</li> <li>• Where possible, use equipment (such as pumps) that are self-bunded;</li> <li>• Spill kit to be present if working around or near a body of water;</li> <li>• Ensure punch list items from the environmental team have been completed prior to working in the area.</li> <li>• If there are concerns about a work area, consult a member of the environmental team and inform a supervisor.</li> <li>• Complete thorough walkthrough of areas prior to work commencing. Record any significant concerns.</li> </ul> <p><b>Construction of ERSED Controls</b></p> <ul style="list-style-type: none"> <li>• Additional ERSED controls not accounted for in the Environmental punch list may be required due to the following activities: <ul style="list-style-type: none"> <li>○ Import of sandstone;</li> <li>○ Access track construction;</li> <li>○ Underbore of Badgery's Creek;</li> <li>○ CSR watermain construction.</li> </ul> </li> <li>• Consult with environmental team and CSR to agree to suitable ERSED Controls for the above activities;</li> <li>• Suitable controls include, but are not limited to: <ul style="list-style-type: none"> <li>○ Earth or Mulch Bunding;</li> <li>○ Rip Rap or Geofabric;</li> <li>○ Spill kit present;</li> <li>○ Bunded storage of fuel or chemicals.</li> </ul> </li> </ul> <p><b>Maintenance of ERSED Controls</b></p> <ul style="list-style-type: none"> <li>• If ERSED controls are damaged due to rain event, work must not recommence until these controls are repaired/replaced.</li> <li>• Damage to ERSED controls due to work activities are to be repaired as soon as possible;</li> <li>• Temporary removal or adjustment of ERSED controls must be communicated and coordinated with supervisors and the environmental team;</li> <li>• No adjustment may be made to ERSED Controls if rain is forecasted within 24 hours;</li> </ul>
------------	---	--

### **Underbore Works**

*Ensure all controls detailed under Point 9 are referred whilst completing this workpack task*

- Access to both sides of Badgery's creek must be made at all times during the underbore process
- Earth Bund to be created around work area at both ends of the underbore;
- Drill Slurry is to be managed with the use of a sucker truck
- Bore plan is to include details of ERSED controls
- In the event of a Frac-out, all works are to stop immediately. Supervisors and environmental team will determine the severity of the frac out and the environmental effect
  - If a frac-out occurs within the first and last 3m of the underbore, stop works and assess the cause. Frac outs are common within this range and are usually not a cause for concern
  - If a frac-out occurs outside the work area, stop works immediately and assess the cause. Verify that no sensitive receivers (residents, other work areas) have been affected and consult with Safety team and supervisors as to when works can recommence.
  - If the Frac-out occurs in an environmentally sensitive area, stop all works immediately and inform the environmental team.
  - It is a requirement that all frac-outs are reported to CPBACCJV. The severity of the frac out will determine the requirement to report to Environmental or safety teams, the Client or to regulators.
  - All frac-outs are considered to be a reportable incident

<p>14.</p>	<p><b>Demobilisation of CSR Watermain</b></p> <p>NPE to remove the CSR watermain and handle offsite disposal.</p> <p>Refer:</p> <ul style="list-style-type: none"> <li>• WSABE-HS-SWMS-0077 - Working over or Around Water</li> <li>• WSABE-HS-SWMS-0078- Working in and Around Mobile Plant</li> <li>• WSABE-HS-SWMS-0079- Installing HDPE Pipe and Fittings</li> </ul>	<p><i>Ensure all controls detailed under point 8 are referred whilst completing this workpack task</i></p> <p><b>Disconnecting Pipe from Pumps</b></p> <ul style="list-style-type: none"> <li>• Ensure all telemetry had been either isolated, disconnected or removed prior to disconnecting any pipework from pumps.</li> <li>• Where possible, purge pipes of all water prior to disconnection. Surcharge water inside the pipe could create unpredictable movements of pipe while unbolting from pumps.</li> </ul> <p><b>Removal of pipework</b></p> <ul style="list-style-type: none"> <li>• Pipe is to be harvested by NPE and transported offsite;</li> <li>• Ensure that pipes are free of water prior to harvesting;</li> <li>• Care must be taken to not damage existing structures – demobilisation of CSR watermain will occur at completion of the WSA Bulk Earthworks.</li> <li>• Earth Bunds are to be removed. Material used for earth bunds must be appropriately re-distributed or disposed of. The Earth bunds are constructed from topsoil, so hand seeding or hydromulching of topsoil is to be completed after removal of pipework.</li> <li>• Pipe is to be cut into lengths of no greater than 20m.</li> <li>• Pipe is to be stockpiled safely; no more than 3 pipes tall and pipe is to be chocked at the bottom every 5m to stop pipe stockpile slipping.</li> </ul>
------------	--	--

**NOTE: Should works or conditions CHANGE in the execution of the works, the works MUST STOP and the process and controls re-assessed and recorded using the pre-start briefing, and/or this work pack.**



## SAFE WORK METHOD STATEMENTS (SWMS)

A SWMS must be developed for all activities that may involve a Business defined High Risk Construction Work task/s.

Identified Risk	Applicable?	SWMS Reference
A risk of a worker or an object falling more than 2 metres	Yes <input checked="" type="checkbox"/> No <input type="checkbox"/>	WSABE-HS-SWMS-0077 WSABE-HS-SWMS-0078 WSABE-HS-SWMS-0083 WSABE-HS-SWMS-0021
The demolition of the whole or part of a structure that is either load-bearing or is related to the physical integrity of a structure	Yes <input type="checkbox"/> No <input checked="" type="checkbox"/>	
Any disturbance of or likely to involve any disturbance of, asbestos	Yes <input type="checkbox"/> No <input checked="" type="checkbox"/>	
Structural alterations or repairs that require temporary support to prevent collapse	Yes <input type="checkbox"/> No <input checked="" type="checkbox"/>	
Work on a telecommunication tower	Yes <input type="checkbox"/> No <input checked="" type="checkbox"/>	
Work in or near a confined space or a shaft or trench that is deeper than 1.5 metres	Yes <input type="checkbox"/> No <input checked="" type="checkbox"/>	
Work in a tunnel	Yes <input type="checkbox"/> No <input checked="" type="checkbox"/>	
The use of explosives	Yes <input type="checkbox"/> No <input checked="" type="checkbox"/>	
Work carried out on or near pressurised gas distribution mains or piping, chemical, fuel or refrigerant lines, or energised electrical installations or services	Yes <input type="checkbox"/> No <input checked="" type="checkbox"/>	
Work in an area that may have a contaminated or flammable atmosphere	Yes <input type="checkbox"/> No <input checked="" type="checkbox"/>	
Tilt-up or precast concrete	Yes <input type="checkbox"/> No <input checked="" type="checkbox"/>	
Work on, in or adjacent to a road, railway (including light rail), shipping lane or other traffic corridor that is in use by traffic other than pedestrians	Yes <input checked="" type="checkbox"/> No <input type="checkbox"/>	WSABE-HS-SWMS-0078
Work in an area where there is any movement of powered mobile plant	Yes <input checked="" type="checkbox"/> No <input type="checkbox"/>	WSABE-HS-SWMS-0078 WSABE-HS-SWMS-0079 WSABE-HS-SWMS-0080 WSABE-HS-SWMS-0021 WSABE-HS-SWMS-0050
Work where there are artificial extremes of temperature	Yes <input type="checkbox"/> No <input checked="" type="checkbox"/>	
Work in or near water or other liquid that involves a risk of drowning	Yes <input checked="" type="checkbox"/> No <input type="checkbox"/>	WSABE-HS-SWMS-0077
Work involving diving work	Yes <input type="checkbox"/> No <input checked="" type="checkbox"/>	
Work that involves Mobile Cranes and Lifting Operations	Yes <input checked="" type="checkbox"/> No <input type="checkbox"/>	WSABE-HS-SWMS-0083 WSABE-HS-SWMS-0078 WSABE-HS-SWMS-0079 WSABE-HS-SWMS-0021

**SAFE WORK METHOD STATEMENTS (SWMS)**

List the SWMS required to be prepared under this work pack (Activity based)

SWMS ID	SWMS Title	CPBACCJV or Subcontractor
WSABE-HS-SWMS-0077	Working over or Around Water	NPE – National Pump and Energy
WSABE-HS-SWMS-0078	Working in and Around Mobile Plant	NPE – National Pump and Energy
WSABE-HS-SWMS-0079	Installing HDPE Pipe and Fittings	NPE – National Pump and Energy
WSABE-HS-SWMS-0080	Maintenance works for HDPE Pipe	NPE – National Pump and Energy
WSABE-HS-SWMS-0083	Underboring works	NPE – National Pump and Energy
WSABE-HS-SWMS-0021	General Earthworks	CPBACCJV
WSABE-HS-SWMS-0050	Load and Unload	CPBACCJV

## SAFETY ESSENTIAL EXCEPTIONS

Are any Safety Essential Exceptions required for this work? No  Yes  If Yes, (Attach Safety Essential Exception Requests);

## STAKEHOLDER NOTIFICATIONS

Are Stakeholders required to be notified for this work? No  Yes  If Yes, By Whom (Attach resulting document);

CSR to be notified of ongoing works inside their areas.

Residents to be notified during stage 1 works for underbore works and connection to CSR Pit

WSA to be notified of works to be carried out within Environmental protection boundaries

WSA to be notified of works beyond CIZ

## ENVIRONMENTAL

List key environmental risks and controls related to the activity:

### Risks:

- 1) Contaminated land
- 2) Potential dust generation.
- 3) Damage to heritage or ecological sites
- 4) Disturbing Asbestos/Unexpected finds
- 5) Noise Generation

### Controls

- 1) Providing GIS to site users to ensure they know where contaminated parts of the site may be, whilst also ensuring no one disturbs the ground to ensure fibres are not put into the air.
- 2) The use of designated haul roads and watercarts for dust suppression.
- 3) Ensure personnel are aware of surroundings and toolboxed at the beginning of each day.
- 4) Unexpected finds protocol – refer WSA10-CPBLLBE-01000-CN-WPK-000006
- 5) Works to be performed during project approved hours 0500 – 2000 where practicable. Refer below Out of hours permits:
  - o Deliveries to be coordinated and appropriate oversize requirements met by the contractor.
    - Out of Hours Permit 'WSA BE -002' for plant deliveries between 6pm to 7am.
    - Out of Hours Permit 'WSA BE -008' for construction activities between 5am to 8pm

Does the activity have Regulated Waste? No  Yes  If Yes, (Attach Details)

Is a Site Environmental Plan applicable to this Work Pack? No  Yes  If Yes, (Include details below & attach)

SEP Doc. No.	Site Environment Plan Title
WSA00-WSA-00400-EN-PLN-000004	Soil and Water - Construction Environmental Management Plan
WSA00-WSA-00400-EN-PLN-000004	Air Quality - Construction Environmental Management Plan

## IDENTIFICATION OF SERVICES

Are services present or positively identified, above, below or within the work area?

No  Yes  If Yes, By Whom (Attach resulting document);

Provide details of service:

Is an isolation required? No  Yes  If Yes, By Whom (Attach resulting document);

Is an Excavation or Penetration Permit Required? No  Yes  If Yes, By Whom (Attach resulting document);

CBPLLJV to provide Excavation or penetration permit when working outside the CiZ or within 10m of the CiZ boundary. Permit to be produced at time of works commencing

## LIFTING

Is a Lift Plan / Study required? No  Yes  If Yes, By Whom (Attach resulting document);

Pre Lift Start card to be filled out each day for lifting of pipe and equipment

Have overhead/underground services been identified? No  Yes  If Yes, By Whom (Attach resulting document);

The majority of services within the CiZ have been identified and removed/decommissioned. Any Necessary Service location and identification will be ongoing based on the staging of the pipeline construction

## PERMITS / APPROVALS REQUIRED

Permits	✓ / ✗	Permit	✓ / ✗
Safety Essentials Exception	<input type="checkbox"/>	Isolation	<input checked="" type="checkbox"/>
Hot Work	<input checked="" type="checkbox"/>	Excavation	<input checked="" type="checkbox"/>
Dewater	<input type="checkbox"/>	Confined Space	<input type="checkbox"/>
Disturb Land	<input checked="" type="checkbox"/>	Enter No-Go Zone	<input checked="" type="checkbox"/>
Permit to Penetrate	<input checked="" type="checkbox"/>	Other (specify)	<input type="checkbox"/>
<i>Add any other activity requiring a permit.</i>			
<b>Other:</b> e.g. Environmental Permit/Approvals – Out of hours works, Planning Permits, EPA license. <i>[Attach Permits and Approvals as applicable]</i>			

## TEMPORARY WORKS

The following temporary works are required for this WORK PACK & need to be designed & certified in accordance with Temporary Works Procedure (e.g. access, special formwork, temporary support). Reference any applicable design/work method documentation.

Type of Temporary Work	Risk Category	Identify relevant approver		
		Designer	Certifier	Inspector
Earth Thrust Blocks	Low	NPE		

### WORK INTERFACE / SIMULTANEOUS OPERATIONS

Detailed interfaces that affect this scope of work, other disciplines, contractors or operations including reference of any specific traffic control and/or logistical requirements.

Interface (Where?)	Party (Who?)	Control/s
Onsite Live Traffic & Pedestrians	NPE CPBACC JV	Prestart communication Exclusion zones enforced Staging and methodology
Heritage Salvage and CSR Pipe installation	NPE CPBACCJV	Prestart communication Exclusion zones enforced Works to only take place following the completion of the heritage salvage
Decontamination Operations	Ocon and PRM	Hygenist and Subcontractor to suitable exclusion zone Weather forecast to be monitored Prestart communication

Is a Vehicle Movement Plan required? No  Yes  If Yes, attach resulting document;

Sitewide VMP will be updated and sent to all subcontractors on a regular basis.

Smaller, area specific VMP's will be produced as required.

### RESOURCE REQUIREMENTS

--

### SURVEY / TESTING REQUIREMENTS

List survey / testing requirements and responsibility

Description of Survey or Testing Required	Resource	When	Frequency
Survey Pickup of Watermain to be completed Daily. Upload to GIS as Live Service	CPBACC JV	Daily	Once

### CONSTRUCTION VERIFICATION

ITP Doc. No.	Inspection and Test Plan Title

### DRAWINGS / SPECIFICATIONS

List a layout drawing and other **relevant** drawings, specifications and standards to clarify above work method.

Ref. No.	Rev	Description / Title

WSA10-CPBLLBE-01000-TW-DRG-000001	D	Water Transfer General Arrangement
WSA10-CPBLLBE-01000-TW-DRG-000021	B	Pump & Standpipe Package General Arrangement
WSA10-CPBLLBE-01000-TW-DRG-000022	B	Road Crossing Details
WSA10-CPBLLBE-01000-TW-DRG-000023	B	Typical Air Valve Detail
WSA10-CPBLLBE-01000-TW-DRG-000024	B	High Capacity Air Valve Details
WSA10-CPBLLBE-01000-TW-DRG-000101	F	Water Transfer Layout (Stage 1)
WSA10-CPBLLBE-01000-TW-DRG-000102	C	Water Transfer Layout Detail (Stage 1)
WSA10-CPBLLBE-01000-TW-DRG-000123	D	Creek Crossing Details
WSA10-CPBLLBE-01000-TW-DRG-000124	D	Discharge Flowmeter & Air Valve Details (Stage 1)
WSA10-CPBLLBE-01000-TW-DRG-000201	C	Water Transfer Layout (Stage 2)
WSA10-CPBLLBE-01000-TW-DRG-000202	C	Water Transfer Layout Detail (Stage 2)
WSA10-CPBLLBE-01000-TW-DRG-000203	B	Manifold Details
WSA10-CPBLLBE-01000-TW-DRG-000204	A	Water Transfer Layout Detail (DB1)
WSA10-CPBLLBE-01000-TW-DRG-000221	A	DB1 Tee Details
WSA10-CPBLLBE-01000-TW-DRG-000301	C	Water Transfer Layout (Stage 3)
WSA10-CPBLLBE-01000-TW-DRG-000302	C	Water Transfer Layout Detail (Stage 3)
WSA10-CPBLLBE-01000-TW-RPT-000001	B	Design Report

**COMMENTS / ADDITIONAL ACTIONS**



**WORK PACK COMPLETION RECORD**

**Comments:**

*< What worked well? What didn't work well? Are there any "Lessons Learnt" improvements? >*

**RESPONSIBLE SUPERVISOR:**

**RESPONSIBLE ENGINEER:**

**Authorisation:**

*The work covered within this WORK PACK has been completed and the records have been checked and are ready for presentation*

*Name*

*Signature*

*Date*

*Responsible Engineer*



## CHECKLIST

*[Insert/attach appendices referenced in this Work Pack here:*

- Work Pack Risk Assessment
- Safe Work Method Statements
- Safety Essential Exceptions Request
- Stakeholder Notifications
- Regulated Waste
- Site Environmental Plan/s
- Identification of Services
- Lift Plan
- Permits / Approvals
- Temporary Works
- Vehicle Movement Plan
- Traffic Control Plan
- Inspection and Test Plans
- Drawings / Specifications
- Other \_\_\_\_\_

## Additional Tables for Installation of HDPE Pipework

### Bolt Torque Settings for HDPE to Butterfly Valves

- The following torque settings only apply to the installation of butterfly valves in HDPE pipe using steel backing rings. Torque settings are independent of pipe pressure rating.

Valve Size (mm)	Target Torque (Nm)
50	45
75	60
100	60
125	90
150	120
200	120
250	155
300	285
350	285
400	285
450	285
500	325
550	365
600	365
650	365
700	365
750	490
800	490
850	490
900	530
1000	630
1050	630
1200	630

Table 1 – Bolt Torque Specifications

### Bolt Tightening Sequence

- The following are tightening sequences.

Number of Bolts	Tightening Sequence
4	1-3-2-4
8	1-5-3-7 >> 2-6-4-8
12	1-7-4-10 >> 2-8-5-11 >> 3-9-6-12
16	1-9-5-13 >> 3-11-7-15 >> 2-10-6-14 >> 4-12-8-16
20	1-11-6-16 >> 3-13-8-18 >> 5-10-15-20 >> 2-12-7-17 >> 4-14-9-19
24	1-13-7-19 >> 4-16-10-22 >> 2-14-8-20 >> 5-17-11-23 >> 3-15-9-21 >> 6-18-12-24
28	1-15-8-22 >> 4-18-11-25 >> 6-20-13-27 >> 2-16-9-23 >> 5-19-12-26 >> 7-21-14-28 >> 3-17-10-24
32	1-17-9-25 >> 5-21-13-29 >> 3-19-11-27 >> 7-23-15-31 > 2-18-10-26 > 6-22-14-30 >> 4-20-12-28 >> 8-24-16-32
36	1-2-3 >> 19-20-21 >> 10-11-12 >> 28-29-30 >> 4-5-6 >> 22-23-24 >> 13-14-15 >> 31-32-33 >> 7-8-9 >> 25-26-27 >> 16-17-18 >> 34-35-36
40	1-2-3-4 >> 21-22-23-24 >> 13-14-15-16 >> 33-34-35-36 >> 5-6-7-8 >> 25-26-27-28 >> 17-18-19-20 >> 37-38-39-40 >> 9-10-11-12 >> 29-30-31-32
44	1-2-3-4 >> 25-26-27-28 >> 13-14-15-16 >> 37-38-39-40 >> 5-6-7-8 >> 29-30-31-32 >> 17-18-19-20 >> 41-42-43-44 >> 9-10-11-12 >> 33-34-35-36 >> 21-22-23-24
48	1-2-3-4 >> 25-26-27-28 >> 13-14-15-16 >> 37-38-39-40 >> 5-6-7-8 >> 29-30-31-32 >> 17-18-19-20 >> 41-42-43-44 >> 9-10-11-12 >> 33-34-35-36 >> 21-22-23-24 >> 45-46-47-48

**Bolt Sizes**

- The following bolt sizes are to be used for Table E backing rings. Bolt length and spacer width is dependent on the butterfly valve type and selected at the discretion of the installer with approval from the construction supervisor.

<b>Pipe OD (mm)</b>	<b>Bolt Size</b>
110	M16
160	M20
200	M20
250	M20
280	M20
315	M24
355	M24
400	M24
500	M24
560	M27
630	M30

**Table 3 – Bolt Size Specifications**

Flange Size Steel to Steel/Poly to Poly.	Bolt size	Newton Metres (Nm)
50mm	M16	43
75mm	M16	61
100mm	M16	61
125mm	M20	90
150mm	M20	90
200mm	M20	119
250mm	M20	119
300mm	M20	155
350mm	M24	285
400mm	M24	285
450mm	M30	285
500mm	M30	285
550mm	M30	325
600mm	M30	366
650mm	M30	366
700mm	M30	366
750mm	M30	366
800mm	M30	488

Assembly instructions for the installation of the Standpipe

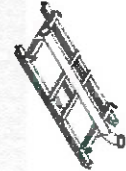

**STEP 1**  
 SELECT A FLAT LEVEL AREA  
 OF SUFFICIENT SIZE TO FACILITATE  
 THE SKID AND A CRANE  
 POSITION SKID BASE

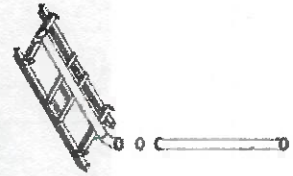

**STEP 2**  
 CRANE THE VERTICAL PIPE INTO POSITION  
 PREPARE THE GASKET AND BOLTS

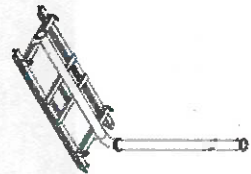

**STEP 3**  
 LOCATE AND BOLT PIPE INTO POSITION  
 ENSURE CORRECT ORIENTATION  
 FOR BRACES

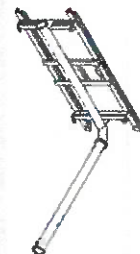

**STEP 4**  
 LAY SKID ON SIDE WITH CRANE  
 SUPPORT WITH STANDS WHERE REQUIRED



**STEP 5**  
 LOCATE AND ATTACH BRACES  
 2 LONG AND 2 SHORT  
 INTO CORRECT POSITIONS



**STEP 6**  
 CRANE TOP PIPE INTO POSITION  
 PREPARE THE GASKET AND BOLTS  
 (IF PIPE EXTENSION IS REQUIRED  
 INSTALL AT THIS STAGE)



**STEP 7**  
 LOCATE AND BOLT PIPE INTO POSITION

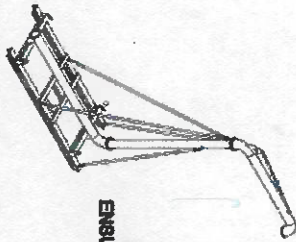

**STEP 8**  
 CRANE THE FILL POINT  
 INTO VERTICAL POSITION  
 ENSURE SLINGS CAN BE REMOVED  
 FROM GROUND

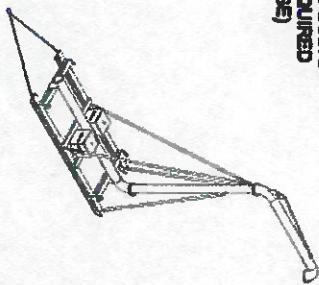

**STEP 9**  
 ATTACH TOW CHAINS  
 LOCATE WEIGHTS  
 FINISH

1	DATE	REVISION



**COPYRIGHT**  
 The copyright in the copyright in the  
 text of this document is held by  
 All Trays B Ltd. All rights reserved.  
 No part of this document may be  
 reproduced without the prior written  
 consent of All Trays B Ltd.



ALL TRAYS AND FABRICATION		
300 FILL POINT	300 FILL POINT	300 FILL POINT
ASSEMBLY	ASSEMBLY	ASSEMBLY
DATE	DATE	DATE
20-224	20-224	20-224
20-040	20-040	20-040

300 FILL POINT BUILD REQUIREMENT		
DATE	DATE	DATE
11:00	20-224-21	1

**ISSUED FOR CONSTRUCTION**

CSR Access Plan

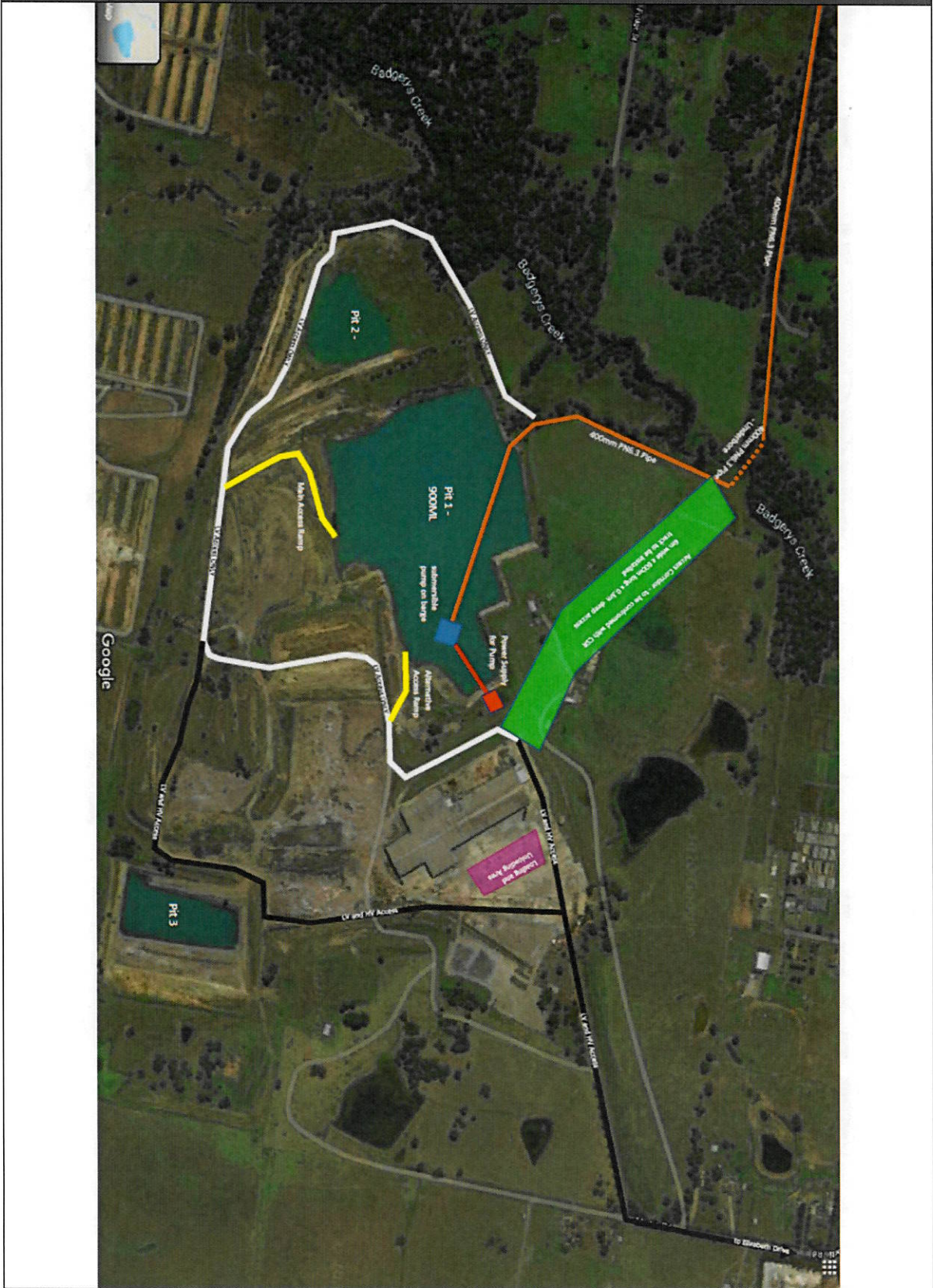

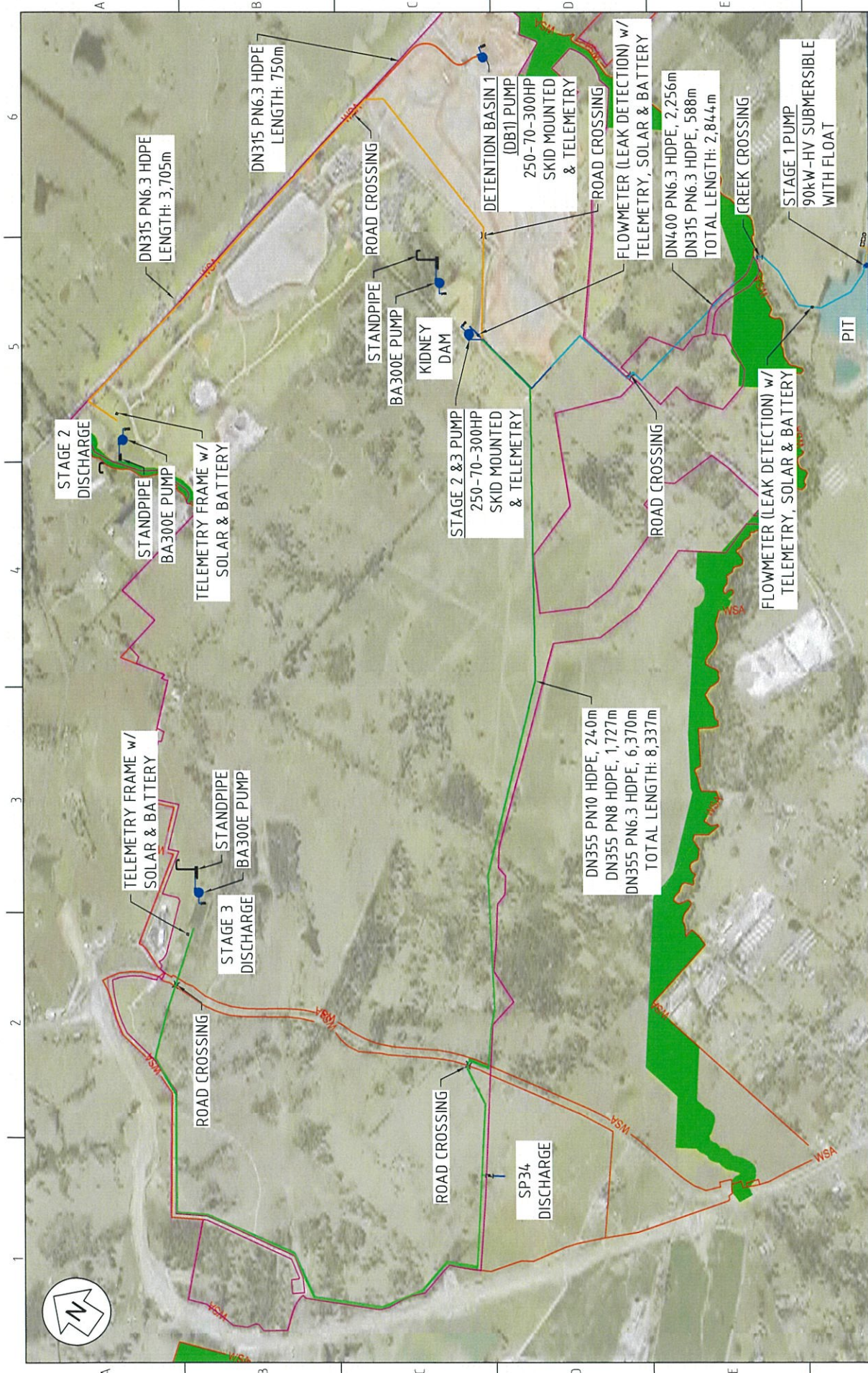

REVISION	DESCRIPTION	DATE	SIGNATURE	CHECKED	THIRD ANGLE PROJECTION	CLIENT	CONTRACTING & LEND LEASE	ISO A3	N.T.S.	SHEET
REV D	FEZ & FEZ ADDED, STAGE 2&3 PUMP LOCATION REVISED	19/06/2020		P.F.		STAN	P FLOOD	DMG SIZE	SCALE	1 of 1
REV 00	APPROVED FOR CONSTRUCTION	03/07/2020		P.F.						
					<small>THIS DRAWING/DATA FILE (AND THE INFORMATION SHOWN THEREIN) IS THE PROPERTY OF NATIONAL PUMP &amp; ELECTRICITY. IT IS TO BE USED ONLY FOR THE PROJECT AND SITE SPECIFICALLY IDENTIFIED IN THE PROJECT TITLE. IT IS NOT TO BE REPRODUCED, COPIED, OR TRANSMITTED IN ANY FORM OR BY ANY MEANS, ELECTRONIC OR MECHANICAL, WITHOUT THE WRITTEN PERMISSION OF NATIONAL PUMP &amp; ELECTRICITY. NATIONAL PUMP &amp; ELECTRICITY ACCEPTS NO LIABILITY FOR OMISSIONS, ERRORS, OR INADEQUACIES IN THE DESIGN, CONSTRUCTION, OR OPERATION OF ANY WORKS OR EQUIPMENT UNDER MANAGEMENT.</small>					

NOTES:  
UNLESS OTHERWISE STATED ALL DIMENSIONS IN MILLIMETERS

WESTERN SYDNEY AIRPORT  
WATER TRANSFER PROJECT  
GENERAL ARRANGEMENT

CONTRACT NO. WSA301-CRILLIIE-00000-1M-DRG-000001  
DRAWING NUMBER





REVISION	DESCRIPTION	DATE	SIGNATURE	CHECKED	THIRD ANGLE PROJECTION	CLIENT	EPB CONTRACTING & LEAD LEASE	SITE	SYDNEY
REV F	ECZ & IZ ADDED	19/06/2020		P.F.		STAN	P FLOOD	ISO A3	NTS
REV 00	APPROVED FOR CONSTRUCTION	03/07/2020		P.F.		DRAWN BY	APPROVED BY	DWG SIZE	SCALE
<p>NOTES:</p> <p>UNLESS OTHERWISE STATED ALL DIMENSIONS IN MILLIMETERS</p>									
<p>WESTERN SYDNEY AIRPORT WATER TRANSFER PROJECT LAYOUT (STAGE 1)</p>									
<p>CONTRACT NO. WSA10-CPBLLBE-01000-TW-DRG-000101 DRAWING NUMBER</p>									
<p>1 OF 1 SHEET</p>									

UNLESS OTHERWISE STATED ALL DIMENSIONS IN MILLIMETERS



REVISION	DESCRIPTION	DATE	SIGNATURE	CHECKED	THIRD ANGLE PROJECTION	CLIENT	CONTRACTING & LEAD LEASE	ISO A3 DWG SIZE	N.T.S. SCALE	SITE
REV A	ISSUED FOR REVIEW	22/04/2020		P.F.		S.T.A.N DRAWN BY	P.FLOOD APPROVED BY	ISO A3 DWG SIZE	N.T.S. SCALE	STUDY
REV B	ISSUED FOR REVIEW	28/04/2020		P.F.						
REV C	ISSUED FOR REVIEW	13/05/2020		P.F.						
REV D	PIPE SIZE AMENDED	20/05/2020		P.F.						
REV E	DRAWING NUMBER REVISED	22/05/2020		P.F.						

NOTES:	UNLESS OTHERWISE STATED ALL DIMENSIONS IN MILLIMETERS
--------	---

  

<p>THESE DRAWINGS, FILES AND THE INFORMATION SHOWN THEREIN IS CONFIDENTIAL AND PROPRIETARY AND SHALL NOT BE REPRODUCED, COPIED, REPRODUCED, OR IN ANY MANNER FOR ANY PURPOSES WITHOUT THE WRITTEN CONSENT OF NATIONAL PUMP &amp; ENERGY ENGINEERING AND DESIGN DEPARTMENT AND/OR MANAGEMENT.</p>	<p>CONTRACT NO. WSA10-CPBLLBE-01000-TW-DRG-000101</p>
--	---

WESTERN SYDNEY AIRPORT  
WATER TRANSFER PROJECT  
LAYOUT (STAGE 1)



1 of 1 SHEET

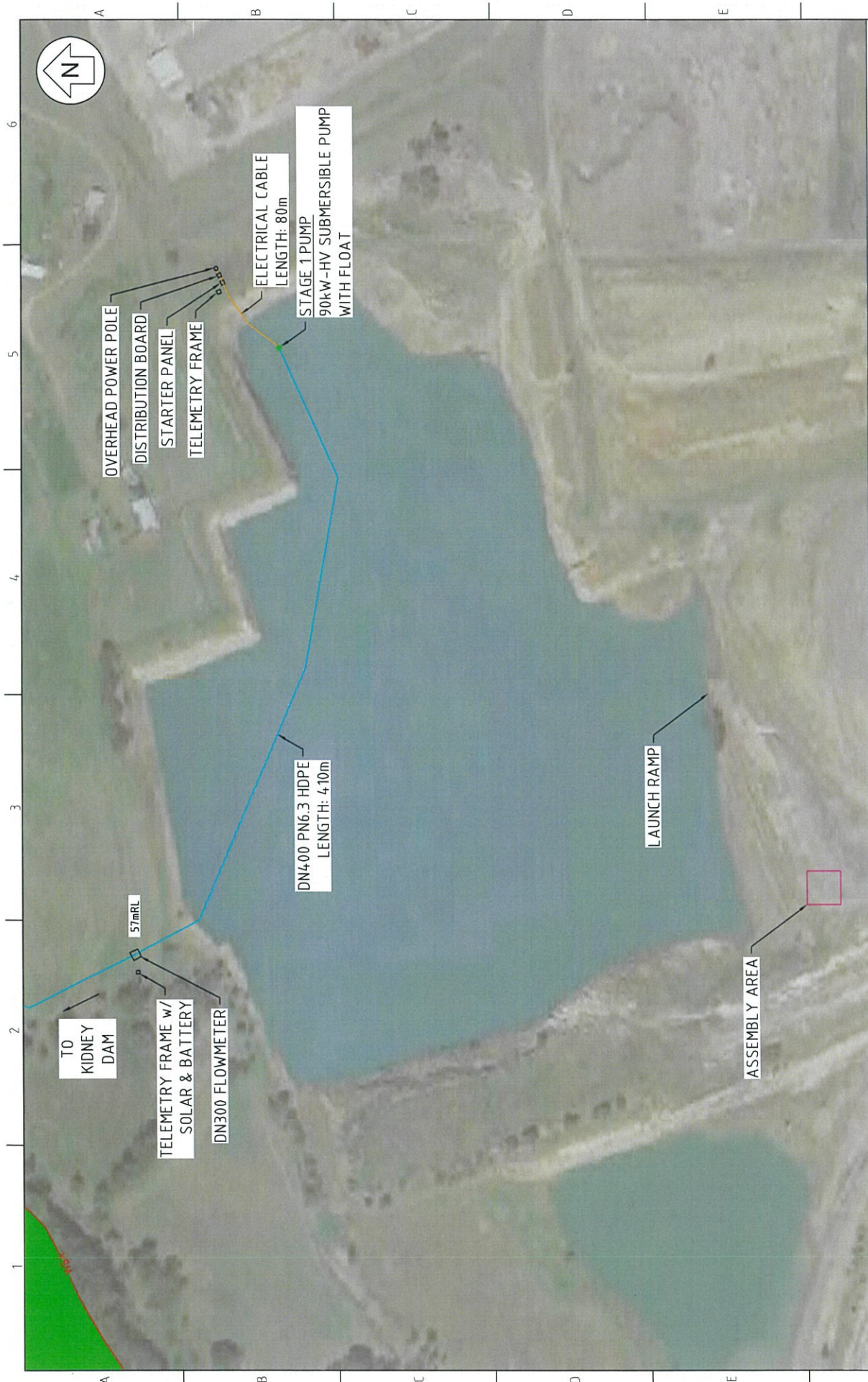

NOTES:		REVISION		DATE		SIGNATURE		CHECKED		THIRD ANGLE PROJECTION		CLIENT		EPB CONTRACTING & LEAD LEASE		SITE		SYDNEY	
UNLESS OTHERWISE STATED ALL DIMENSIONS IN MILLIMETERS		REV C	DRAWING NUMBER REVISED	22/05/2020	P.F.			P.F.				S.TAN	P FLOOD	ISO A3	NTS	WESTERN SYDNEY AIRPORT WATER TRANSFER PROJECT LAYOUT DETAIL (STAGE 1)			
		REV 00	APPROVED FOR CONSTRUCTION	03/07/2020	P.F.			P.F.				DRAWN BY	APPROVED BY	DWG SIZE	SCALE	CONTRACT NO. KIS30-EPB/LE-01000-1W-DRG-000102 DRAWING NUMBER 6			
																1 of 1 SHEET			



THE DRAWING IS AVAILABLE AND THE INFORMATION SHOWN HEREIN IS FOR INFORMATION ONLY AND IS NOT TO BE USED FOR CONSTRUCTION. ANY INFORMATION SHOWN HEREIN IS SUBJECT TO THE TERMS AND CONDITIONS OF THE CONTRACT AND SHALL BE THE PROPERTY OF EPB CONTRACTING AND BEYOND DEPARTMENT AND/OR MANAGEMENT.

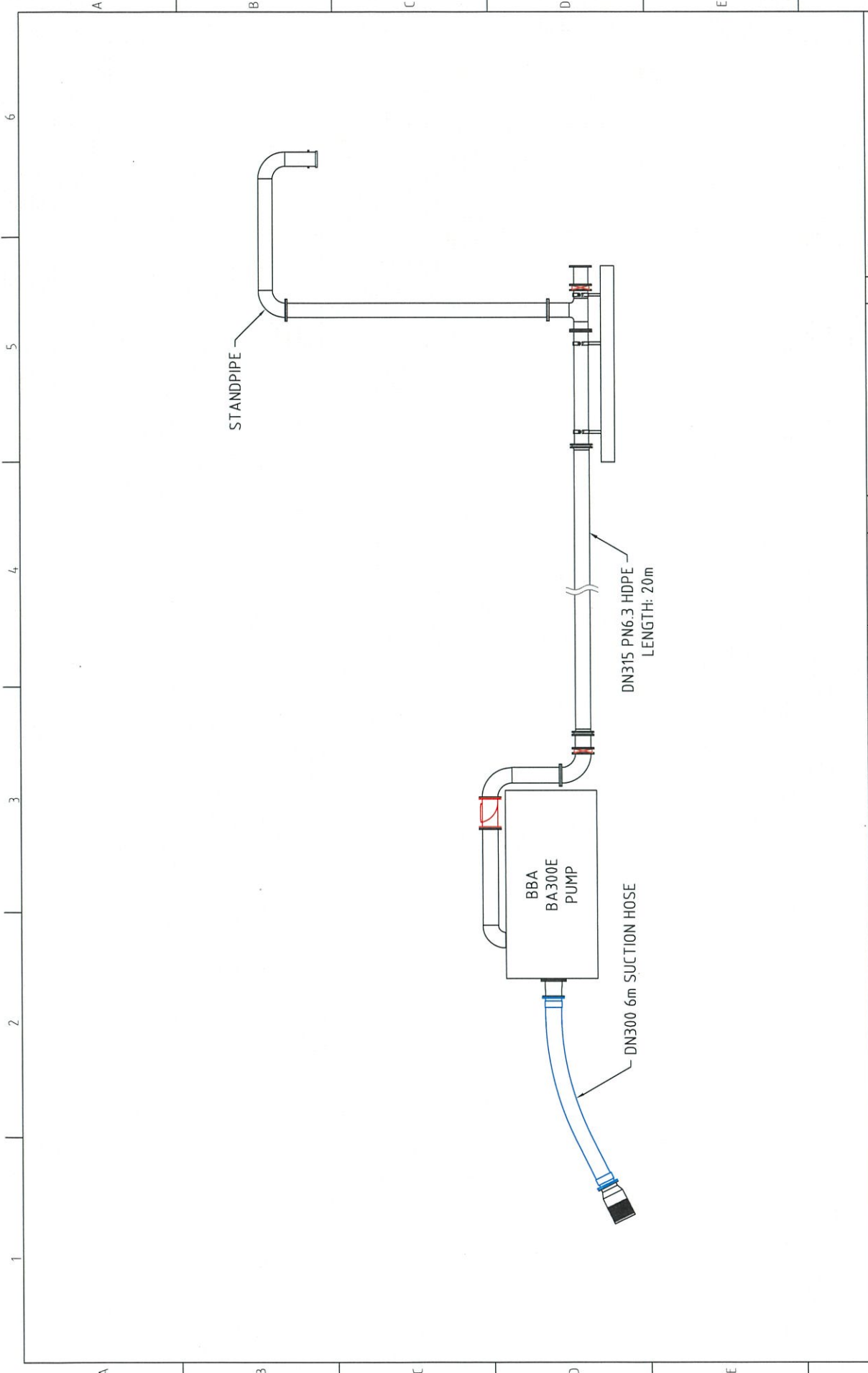

STANDPIPE

BBA  
BA300E  
PUMP

DN300 6m SUCTION HOSE

DN315 PN6.3 HDPE  
LENGTH: 20m

NOTES:		UNLESS OTHERWISE STATED ALL DIMENSIONS IN MILLIMETERS	
REVISION	DESCRIPTION	DATE	SIGNATURE
REV B	DRAWING NUMBER REVISED	22/05/2020	P.F.
REV 00	APPROVED FOR CONSTRUCTION	03/07/2020	P.F.
THIRD ANGLE PROJECTION		CLIENT	CPB CONTRACTING & LEAD LEASE
		STAN DRAWN BY	P.F.0000
<small>THIS DRAWING DATA FILE AND THE INFORMATION SHOWN HEREIN IS UNCLASSIFIED AND IS NOT TO BE REPRODUCED OR TRANSMITTED IN ANY FORM OR BY ANY MEANS, WITHOUT EXPRESS PERMISSION OF THE AIRPORT AUTHORITY OF WESTERN SYDNEY AND DESIGN DEPARTMENT AND/OR MANAGEMENT.</small>		APPROVED BY	PF.0000
		WESTERN SYDNEY AIRPORT PUMP & STANDPIPE PACKAGE GENERAL ARRANGEMENT	
NATIONAL PUMP & ENERGY		CONTRACT NO.	WSA10-CPHILLIC-0000-1W-DRG-00021
SITE: SYDNEY		DRAWING NUMBER	6
ISO A3 DRG SIZE		1/1'S SCALE	1 OF 1 SHEET

1 2 3 4 5 6

A A

B B

C C

D D

E E

F F

60m shown as an indicative minimum  
Actual Underbore expected to be 90-100m. Refer to proposed creek crossing Natural Surface

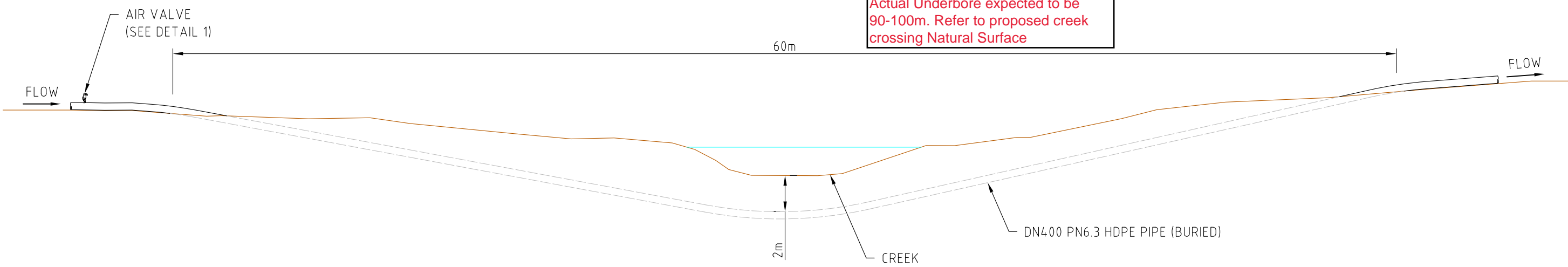

2m is a minimum based off length of underbore.  
Underbore increase to 90-100m will increase the depth under the creek to 2.8-3.0m.

ELEVATION VIEW

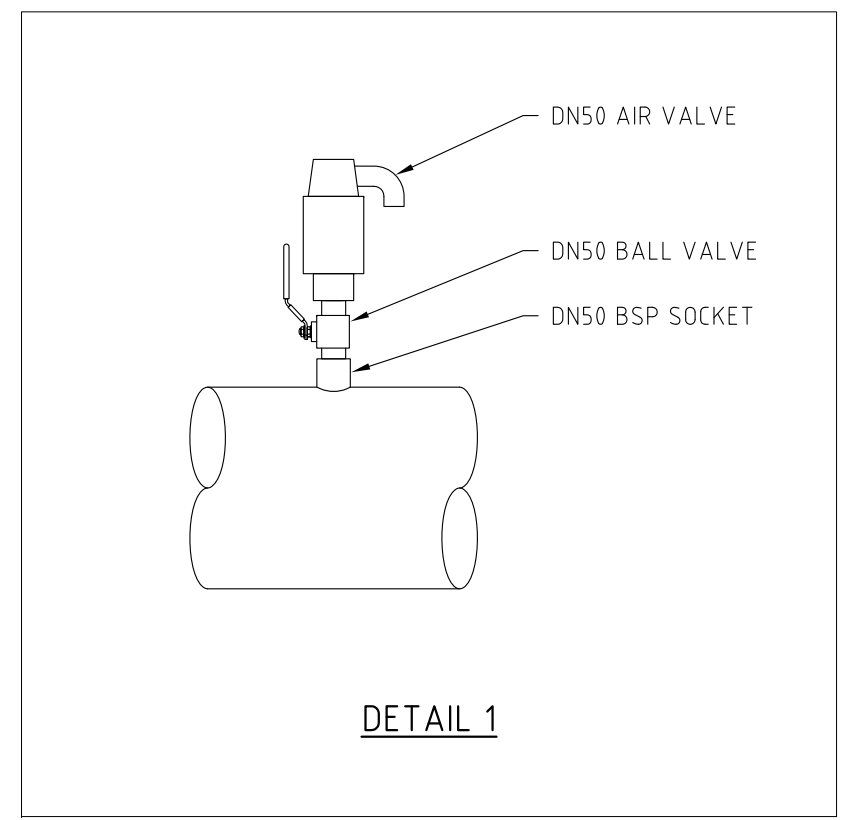

DETAIL 1

NOTES:  
UNLESS OTHERWISE STATED ALL DIMENSIONS IN MILLIMETERS

REVISION	DESCRIPTION	DATE	SIGNATURE	CHECKED
REV D	DRAWING NUMBER REVISED	22/05/2020		P.F.
REV 00	APPROVED FOR CONSTRUCTION	03/07/2020		P.F.

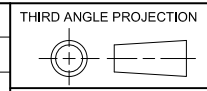

THIS DRAWING/DATA FILE (AND THE INFORMATION SHOWN THERE ON) IS CONFIDENTIAL & PROPRIETARY AND SHALL NOT BE USED, DISCLOSED TO OTHERS OR REPRODUCED BY ANY MEANS FOR ANY PURPOSE IN HARD COPY FORM OR IN MACHINE READABLE FILES, WITHOUT FORMAL WRITTEN CONSENT OF NATIONAL PUMP AND ENERGY ENGINEERING AND DESIGN DEPARTMENT AND/OR MANAGEMENT.

CLIENT	CPB CONTRACTING & LEND LEASE
S.TAN DRAWN BY	P.FLOOD APPROVED BY



SITE	SYDNEY
WESTERN SYDNEY AIRPORT CREEK CROSSING DETAILS	
- CONTRACT NO.	WSA10-CPBLLBE-01000-TW-DRG-000121
	DRAWING NUMBER
	1 of 1 SHEET

1 2 3 4 5 6

Underbore Pipe  
 Floodzone is ar RL 54 for 100 year Rainfall.  
 Start and end of underbore to be outside the floodplain.

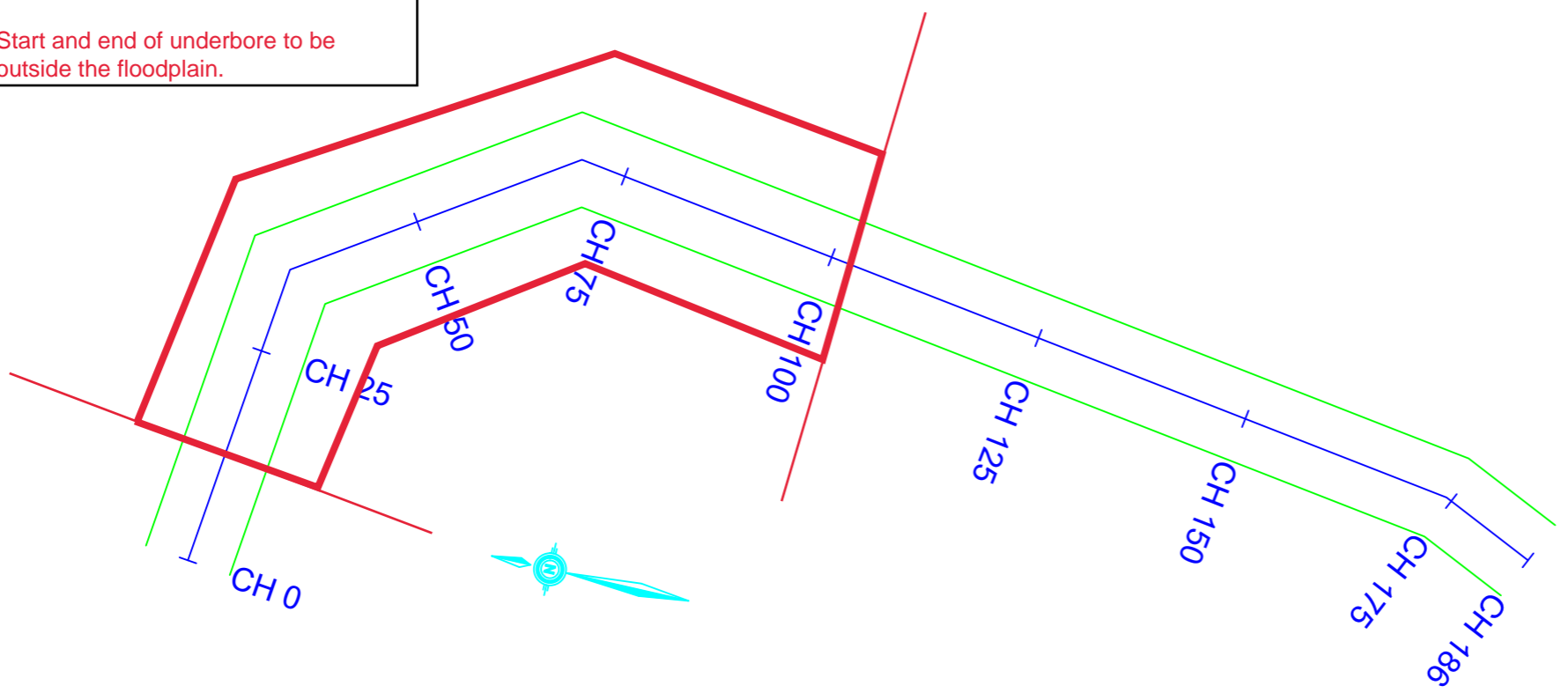

Datum 42

Natural Surface	54.88	54.8	54.42	53.99	53.77	52.98	52.04	51.51	50.16	50.9	52.01	52.23	52.72	53	53.13	53.4	53.63	53.78	53.84	53.99	54.08	54.14	54.22	54.26	54.42	54.36	54.33	54.58	54.85	54.82	54.99	55	55.15	55.19	55.01	55.24	55.4	55.3	55.24
Chainages	0	5	10	15	20	25	30	35	40	45	50	55	60	65	70	75	80	85	90	95	100	105	110	115	120	125	130	135	140	145	150	155	160	165	170	175	180	185	185.92

REV	ZONE	AMENDMENTS	APPD	DATE	GENERAL NOTES / REFERENCES

SURVEYED / DRAWN BY BH	PLOT DATE: Fri Apr 17 20:17:06 2020	LOCATION:
COORDINATE SYSTEM MGA Zone 56		
HEIGHT DATUM A.H.D	<b>Proposed CSR Water Main</b> <b>Badgerys Creek Crossing</b>	
SCALE 1:		
SHEET 1 of 1		200417

CPBLLV/MSA

Project: Test

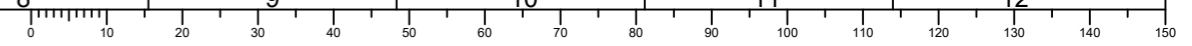

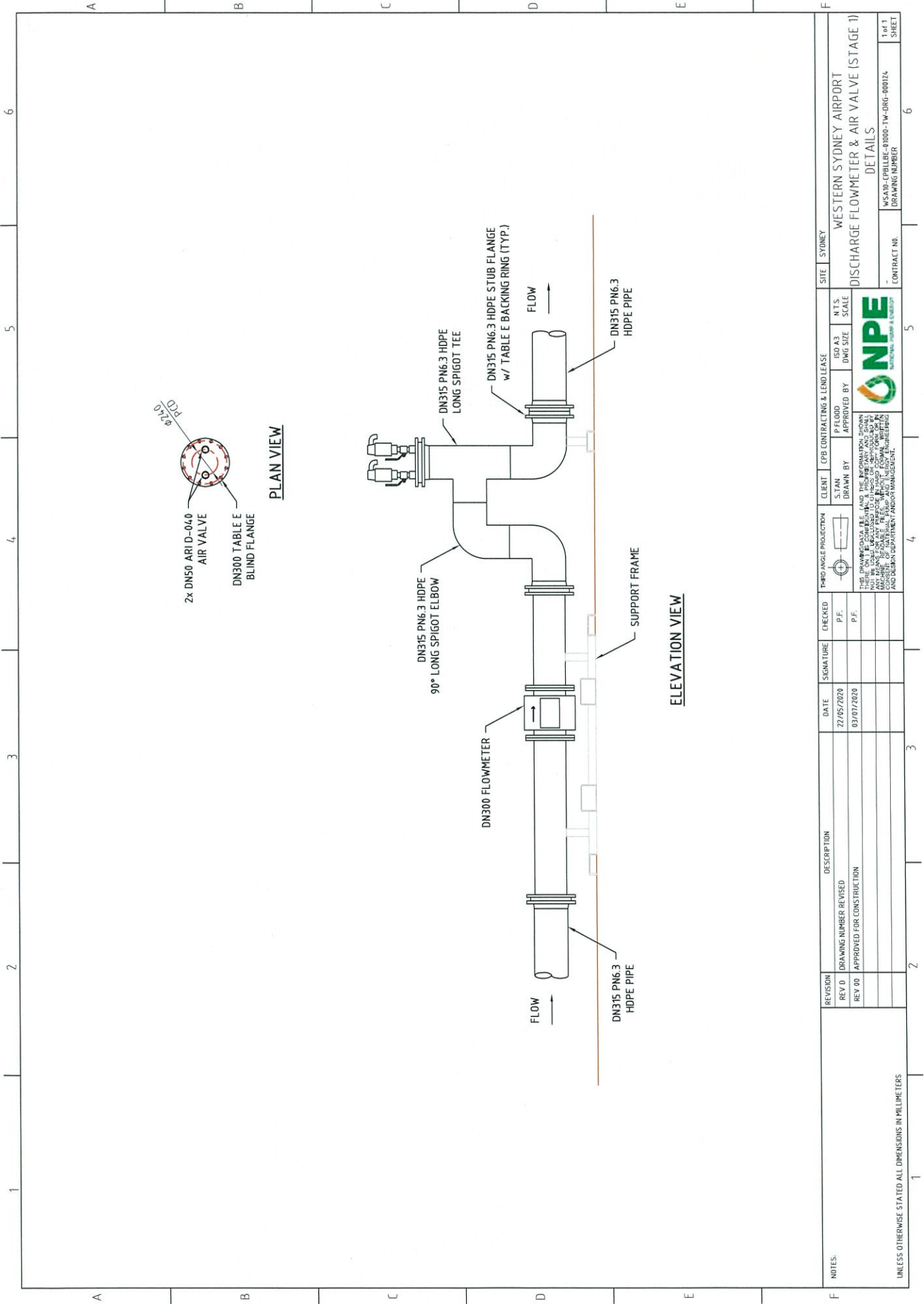

NOTES:		DATE		SIGNATURE		CHECKED		THIRD ANGLE PROJECTION		CLIENT		EPC CONTRACTING & LEAD LEASE		SITE	
REV 00	DRAWING NUMBER REVISED	27/05/2020	P.F.						S.T.A.N	WESTERN SYDNEY AIRPORT	SYDNEY	ISO A3	N.T.S.	WESTERN SYDNEY AIRPORT	
REV 00	APPROVED FOR CONSTRUCTION	03/07/2020	P.F.						APPROVED BY	DISCHARGE FLOWMETER & AIR VALVE (STAGE 1)		DMG SIZE	SCALE	DETAILS	
THIS DRAWING, DATA FILE, AND THE INFORMATION SHOWN HEREON IS THE PROPERTY OF NATIONAL PIPE & FLANGE. IT IS NOT TO BE USED, REPRODUCED, COPIED, OR TRANSMITTED IN ANY FORM OR BY ANY MEANS, WITHOUT THE WRITTEN PERMISSION OF NATIONAL PIPE & FLANGE. NATIONAL PIPE & FLANGE IS AN ISO 9001:2015 CERTIFIED COMPANY AND DESIGN DEPARTMENT AND/OR MANAGEMENT.										CONTRACT NO.		DRAWING NUMBER		1 of 1 SHEET	
UNLESS OTHERWISE STATED ALL DIMENSIONS IN MILLIMETERS										MS&AP-CHILLER-0000-TM-DRG-000124		5		6	



KIDNEY DAM

TO DISCHARGE

DN300 SUCTION STRAINER  
w/ DN300 90° BEND

4500L FUEL TANK  
TELEMETRY FRAME w/  
SOLAR & BATTERY

PIPE FLOAT  
DN315 PN10 HDPE PIPE  
LENGTH: 4.0m

STAGE 2 PUMP  
250-70-300HP  
SKID MOUNTED

DN355 PN10 HDPE PIPE  
LENGTH: 90m

DN315 PN6.3 HDPE  
LENGTH: 3,705m

MANIFOLD DETAILS  
(DRG NO. WSA10-CPBLLBE-01000-TW-DRG-000203)



REVISION	DESCRIPTION	DATE	SIGNATURE	CHECKED	THIRD ANGLE PROJECTION	CLIENT	EPB CONTRACTING & LEAD LEASE	SITE	SHEET
REV C	PUMP LOCATION REVISED	19/06/2020		P.F.		S.T.A.N DRAWN BY	P FLOOD APPROVED BY	SYDNEY	1 of 1
REV 00	APPROVED FOR CONSTRUCTION	03/07/2020		P.F.					
NOTES: UNLESS OTHERWISE STATED ALL DIMENSIONS IN MILLIMETERS									

ISO A3  
DMG SIZE

N.T.S.  
SCALE

WESTERN SYDNEY AIRPORT  
WATER TRANSFER PROJECT  
LAYOUT DETAIL (STAGE 2)

CONTRACT NO. WSA10-CPBLLBE-01000-TW-DRG-000202  
DRAWING NUMBER



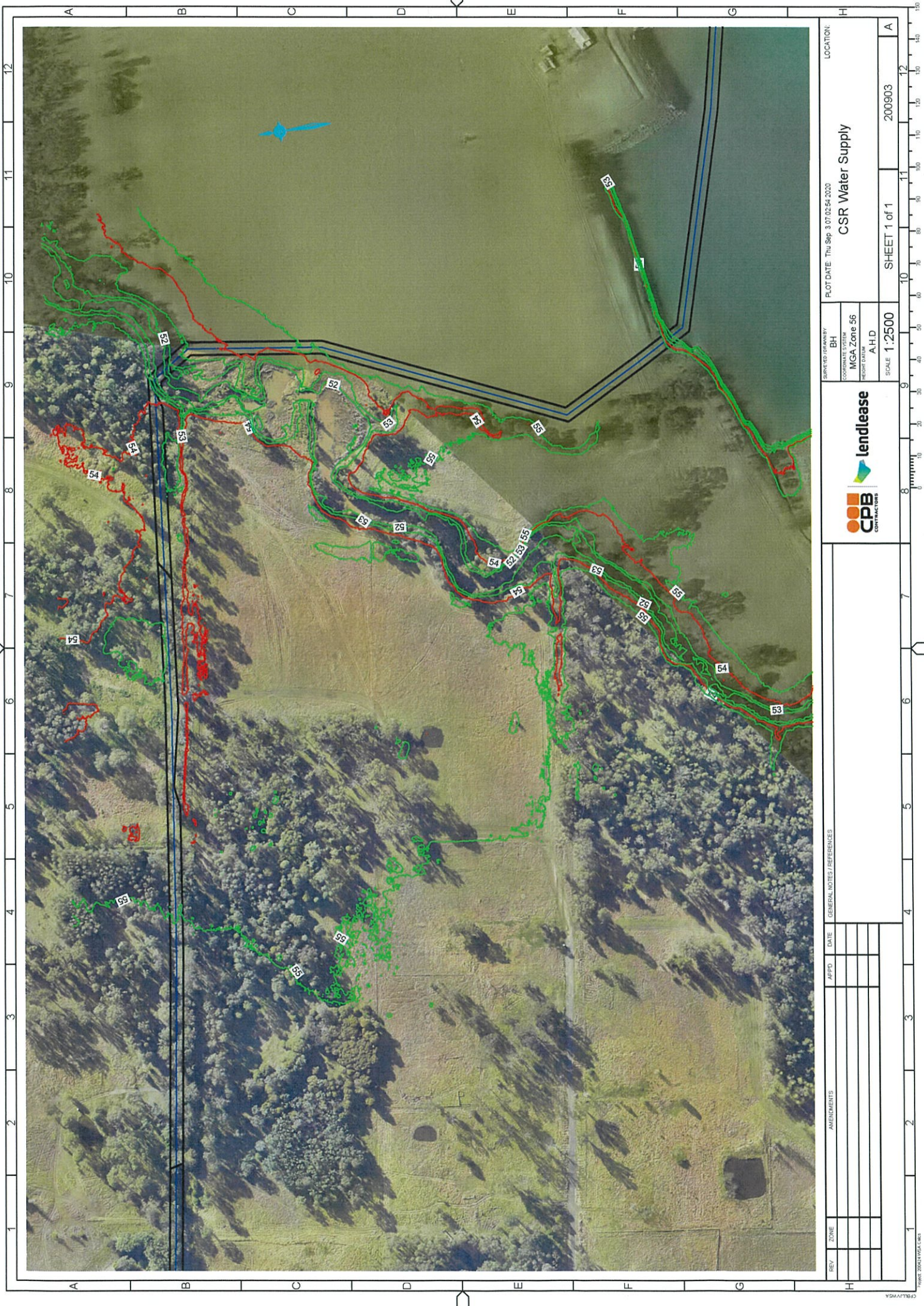

LOCATION: 200903

SAVED DRAWING: BH

PLOT DATE: Thu Sep 3 07:02:54 2020

COORDINATE SYSTEM: MGA, Zone 56

REPORT DATUM: A.H.D.

SCALE: 1:2500

SHEET 1 of 1

200903

**lendlease**

**CPB CONTRACTORS**

REV	ZONE	AMENDMENTS	APPD	DATE	GENERAL NOTES / REFERENCES

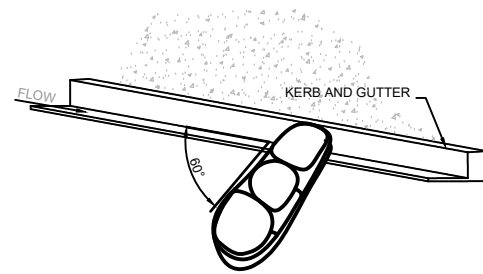

### GRAVEL FILLED SAUSAGE TEMPORARY GUTTER GROSS POLLUTANT/SEDIMENT TRAP

SCALE NTS  
COARSE GRAVEL ROLLED IN NETTING MATERIAL TOTALING 200mm  
HIGH 7 PLACED HARD AGAINST FACE OF KERB.

NOTE:  
SEDIMENT BARRIERS TO BE USED ONLY WHERE ROAD WIDTHS  
PERMITS AND WHERE SAFETY TO PASSING TRAFFIC IS NOT AFFECTED

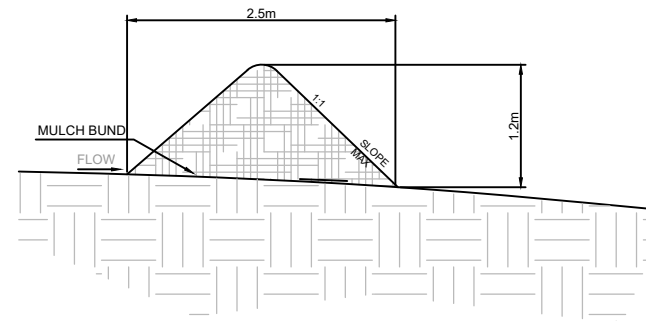

### CONSTRUCTION NOTES:

1. A TYPE OF 2 SEDIMENT TRAP
2. SHEET FLOW CONDITIONS ONLY
3. SUITABLE FOR ALL SOIL TYPES
4. COMPOST BERMS MAY EITHER BE FREE STANDING OR CONTAINED WITHIN A SOCK
5. CAN PERFORM BETTER THAN A TRADITIONAL SEDIMENT FENCE, BUT ONLY WHILST THE BERM REMAINS UNDAMAGED.

### MULCH BUND SEDIMENT TRAP

SOURCE: MANAGING URBAN STORMWATER  
SOILS AND CONSTRUCTION FOURTH EDITION,  
MARCH 2004 PRODUCED BY THE DEPARTMENT  
OF HOUSING

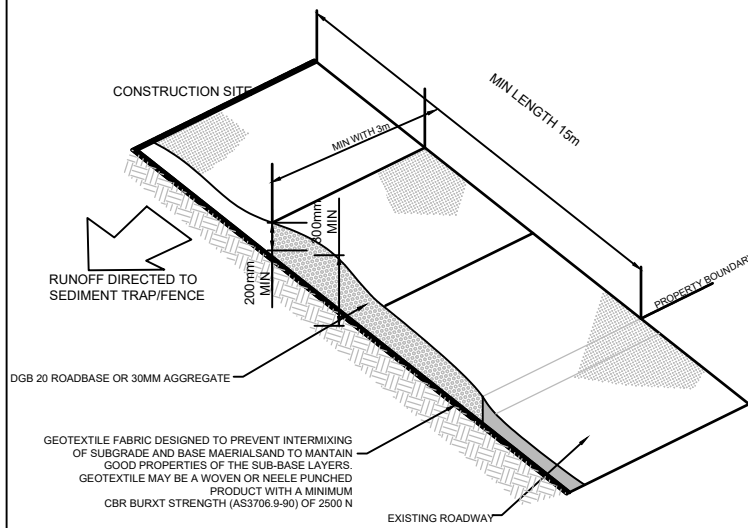

### CONSTRUCTION NOTES:

1. STRIP THE TOPSOIL, LEVEL THE SITE AND COMPACT THE SUBGRADE.
2. COVER THE AREA WITH NEEDLE-PUNCHED GEOTEXTILE.
3. CONSTRUCT A 200MM TICK PAD OVER THE GEOTEXTILE USING ROAD BASE OR 30MM AGGREGATE.
4. ENSURE THE STRUCTURE IS AT LEAST 15 METERS LONG OR TO BUILDING ALIGNMENT AND AT LEAST 3 METER WIDE.
5. WHERE A SEDIMENT FENCE JOINTS ONTO THE STABILIZED ACCESS, CONSTRUCT A HUMP IN THE STABILIZED ACCESS TO DIVERT WATER TO THE SEDIMENT FENCE.

### STABILIZED SIDE ACCESS SD 6-14

SOURCE: MANAGING URBAN STORMWATER  
SOILS AND CONSTRUCTION FOURTH EDITION,  
MARCH 2004 PRODUCED BY THE DEPARTMENT  
OF HOUSING

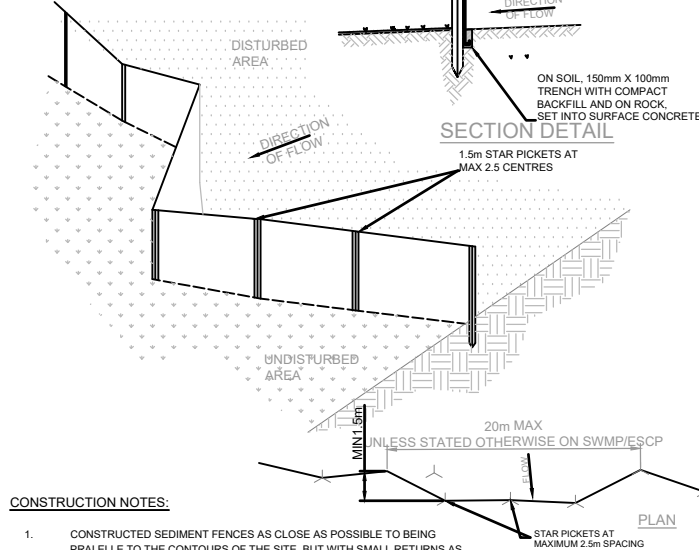

### CONSTRUCTION NOTES:

1. CONSTRUCTED SEDIMENT FENCES AS CLOSE AS POSSIBLE TO BEING PARALLEL TO THE CONTOURS OF THE SITE, BUT WITH SMALL RETURNS AS SHOWN IN THE DRAWING TO LIMIT THE CATCHMENT AREA OF ANY ONE SECTION. THE CATCHMENT AREA SHOULD BE SMALL ENOUGH TO LIMIT WATER FLOW IF CONCENTRATED AT ONE POINT TO 50 LITERS PER SECOND IN THE DESIGN STORM EVENT, USUAL THE 10 YEAR EVENT.
2. CUT A 150MM DEEP TRENCH ALONG THE UPSLOPE LINE OF THE FENCE FOR THE BOTTOM OF THE FABRIC TO BE ENTRENCHED.
3. DRIVE 1.5 METER LONG STAR PICKETS INTO GROUND AT 2.5 METER INTERVALS (MAX) AT THE DOWNSLOPE EDGE OF THE TRENCH. ENSURE ANY STAR PICKETS ARE FITTED WITH SAFETY CAPS.
4. FIX SELF-SUPPORTING GEOTEXTILE TO THE UPSLOPE SIDE OF THE POST ENSURING IT GOES TO THE BASE OF THE TRENCH, FIX THE GEOTEXTILE WITH WIRE TIES OR AS RECOMMENDED BY THE MANUFACTURER. ONLY USE GEOTEXTILE SPECIALLY PRODUCED FOR SEDIMENT FENCING. THE USE OF SHADE CLOTH FOR THIS PURPOSE IS NOT SATISFACTORY.
5. JOIN SECTION OF FABRIC AT A SUPPORT POST WITH A 150 MM OVERLAP.
6. BACK FILL TRENCH OVER THE BASE OF THE FABRIC AND COMPACT IT THOROUGHLY OVER THE GEOTEXTILE.

### SEDIMENT FENCE SD 6-8

SOURCE: MANAGING URBAN STORMWATER  
SOILS AND CONSTRUCTION FOURTH EDITION,  
MARCH 2004 PRODUCED BY THE DEPARTMENT  
OF HOUSING

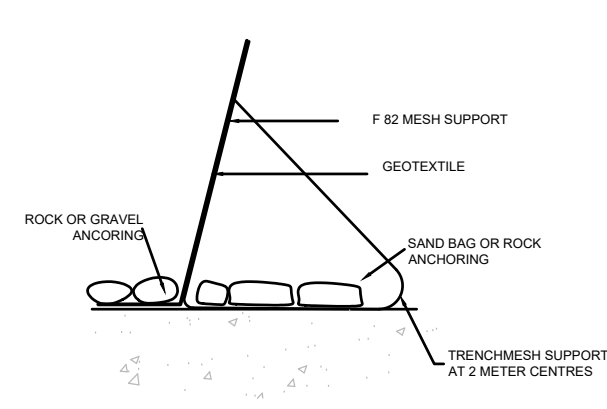

### CONSTRUCTION NOTES:

1. INSTALL THIS TYPE OF SEDIMENT FENCE WHEN USE OF SUPPORT POSTS IS NOT DESIRABLE OR NOT POSSIBLE. SUCH CONDITIONS MIGHT APPLY, FOR EXAMPLE, WHERE APPROVAL IS GRANTED FROM THE APPROPRIATED AUTHORITIES TO PLACE THESE FENCES IN HIGHLY SENSITIVE ESTUARINE AREAS.
2. USE BENT TRENCH MESH TO SUPPORT THE F82 WELDED MESH FACING AS SHOWN ON THE DRAWING ABOVE. ATTACHE THE GEOTEXTILE TO WELDED MESH FACING USING UV RESISTANT CABLE TIES.
3. STABILIZE THE WHOLE STRUCTURE WITH SANDBAG OR ROCK ANCHORING OVER THE TRENCH MESH AND THE LEADING EDGE OF THE GEOTEXTILE. THE ANCHORING SHOULD BE SUFFICIENTLY LARGE TO ENSURE STABILITY OF THE STRUCTURE IN THE DESIGN STORM EVENT, USUALLY THE 10 YEAR EVENT.

### ALTERNATIVE SEDIMENT FENCE SD 6-9

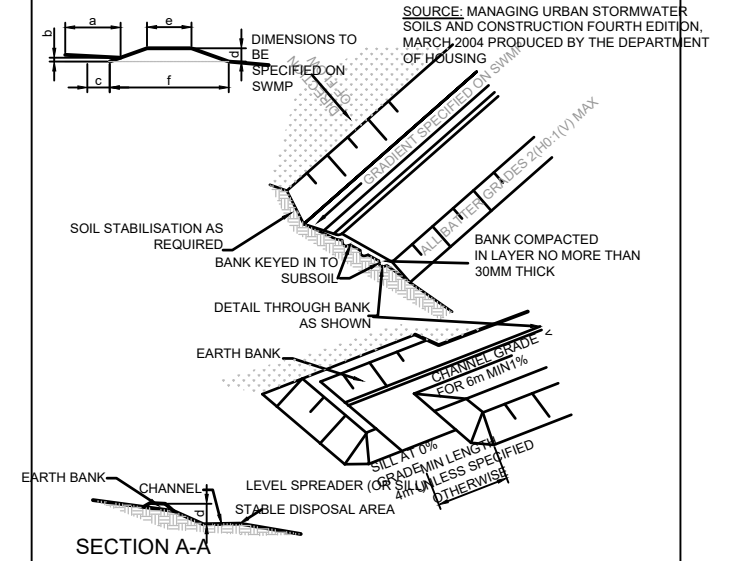

### CONSTRUCTION NOTES:

1. CONSTRUCTION AT THE GRADIENT SPECIFIED ON THE ESCP OR SWMP. NORMALLY BETWEEN 1 AND 5 PERCENT.
2. AVOID REMOVING TREES AND SHRUBS IF POSSIBLE - WORK AROUND THEM.
3. ENSURE THE STRUCTURE ARE FREE OF PROJECTIONS OR OTHER IRREGULARITIES THAT COULD IMPEDE WATER FLOW.
4. BUILD THE DRAINS WITH CIRCULAR, PARABOLIC OR TRAPEZODIAL CROSS SECTION, NOT V - SHAPED, AT THE DIMENSIONS SHOWN ON THE SWMP.
5. ENSURE THE BANKS ARE PROPERLY COMPACTED TO PREVENT FAILURE.
6. COMPLETE PERMANENT OR TEMPORARY STABILIZATION WITHIN 10 DAYS OF CONSTRUCTION FOLLOWING TABLE 5.2 IN LANDCOM.
7. WHERE DISCHARGING TO ERODIBLE LANDS, ENSURE THEY OUTLET THROUGH A PROPERLY CONSTRUCTED LEVEL SPREADER.
8. CONSTRUCT THE LEVEL SPREADER AT THE GRADIENT SPECIFIED ON THE ESCP OR SWMP, NORMALLY LESS THAN 1 PERCENT OR LEVEL.
9. WHERE POSSIBLE, ENSURE THEY DISCHARGE WATERS ONTO EITHER STABILIZED OR UNDISTURBED DISPOSAL SITED WITHIN THE SAME SUBCATCHMENT AREA FROM WHICH THE WATER ORIGINATED. APPROVAL MIGHT BE REQUIRED TO DISCHARGE INTO OTHER SUBCATCHMENTS.

### EARTHBANK (HIGH FLOWS)SD5-6

TITLE: SEDIMENTATION AND EROSION CONTROL PLANS  
BADGERYS CREEK

SEDIMENTATION AND EROSION DETAILS

CLIENT: CSR

### NOTE:

ALL EXISTING UNDERGROUND SERVICES MUST BE LOCATED AND EXPOSED PRIOR TO EARTHWORKS COMMENCING AND IT IS RESPONSIBILITY OF THOSE PERSONS USING THIS PLAN TO CONFIRM BOTH POSITION AND LEVEL OF THESE UTILITIES IN CONJUNCTION WITH THE APPROPRIATE AUTHORITY.

Date: 30.08.20 Scale:  
Cad Ref: SED PLANS

Designed:

Project No  
**CSR**

No	Amendment	Drawn	Date
1	CLIENT ISSUE	KU	30.08.20

Drawing No	Revision
01	1